



ADEX
since 1897



 QUICK REFERENCE GUIDE V105

QUICK REFERENCE GUIDE V105

COLLECTIONS

NERI Solid Glaze	04
STUDIO Translucent Glaze	22
RIVIERA Multi Tone Glaze	30
HABITAT Glossy & Matte Glaze	40
EARTH Matte Crackle	50
OCEAN Micro Crackle	54
HAMPTON Classic Crackle	58
DIAMONDS Dimensional Field	64
MOSAIC	66
FLOOR	
Glazed Porcelain Tiles (39% Recycled)	70
Glass Floor Tiles (98% Recycled)	74

CUSTOM SHOP	76
--------------------	----

INSTALLATION & MAINTENANCE	78
---------------------------------------	----

TECHNICAL GUIDE	81
------------------------	----

NERI Solid Glaze Glossy Finish

WHITE

Find out the product code simply by putting together the color and the item

Example: **ADNZ** **836**

FIELD TILES

FLAT

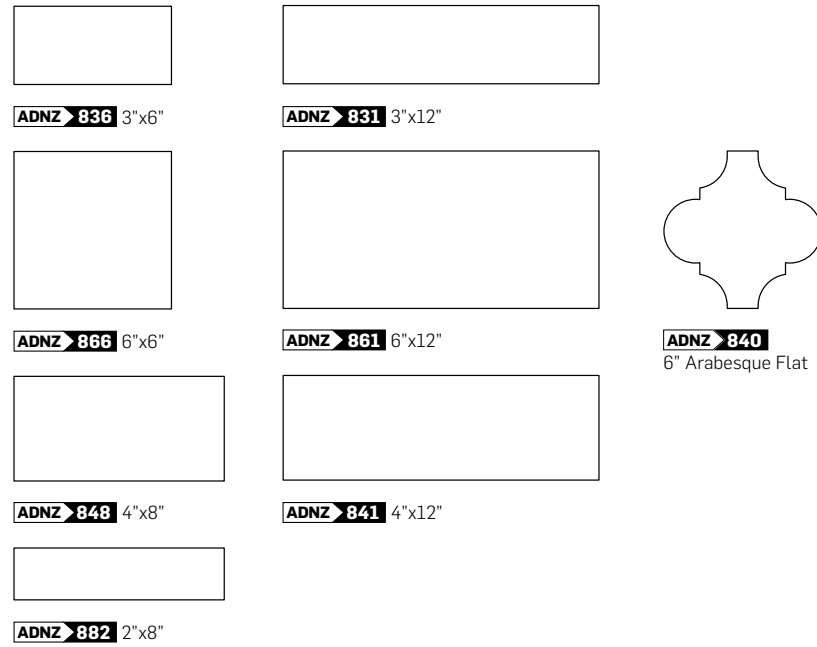

TRIMS

FINISHING EDGES



ADNZ 508 FE 0.4"x6"
ADNZ 508 FE 0.4"x8"
ADNZ 500 FE Corner

BULLNOSES

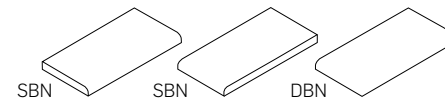

ADNZ 805 3"x6" SBN 6"
ADNZ 806 3"x6" SBN 3"
ADNZ 807 3"x6" DBN Right
ADNZ 808 3"x6" DBN Left
ADNZ 803 6"x6" SBN
ADNZ 804 6"x6" DBN
ADNZ 810 4"x8" SBN 4"
ADNZ 811 4"x8" SBN 8"
ADNZ 812 4"x4" DBN
ADNZ 800 2"x2" DBN
ADNZ 826 2"x6" SBN 6"
ADNZ 828 2"x8" SBN 8"

GLAZED EDGES

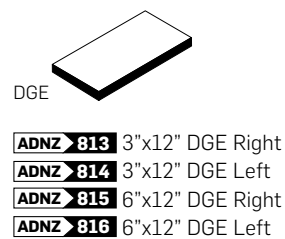

BEVELED

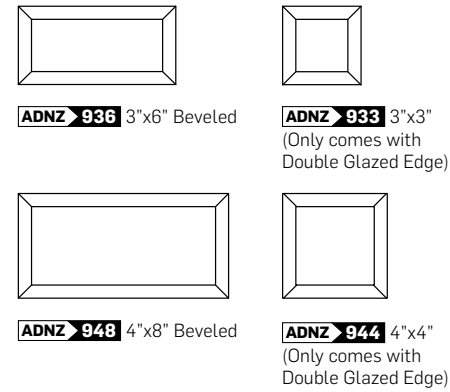

TRIMS

BEVELED GLAZED EDGES

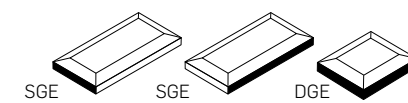

ADNZ 907 3"x6" Beveled SGE 3"
ADNZ 908 3"x6" Beveled SGE 6"
ADNZ 933 3"x3" Beveled DGE
ADNZ 911 4"x8" Beveled SGE 4"
ADNZ 910 4"x8" Beveled SGE 8"
ADNZ 944 4"x4" Beveled DGE

NERI Solid Glaze Glossy Finish

WHITE

Find out the product code simply by putting together the color and the item

Example: **ADNZ** **836**

DECORATIVE ACCESSORIES

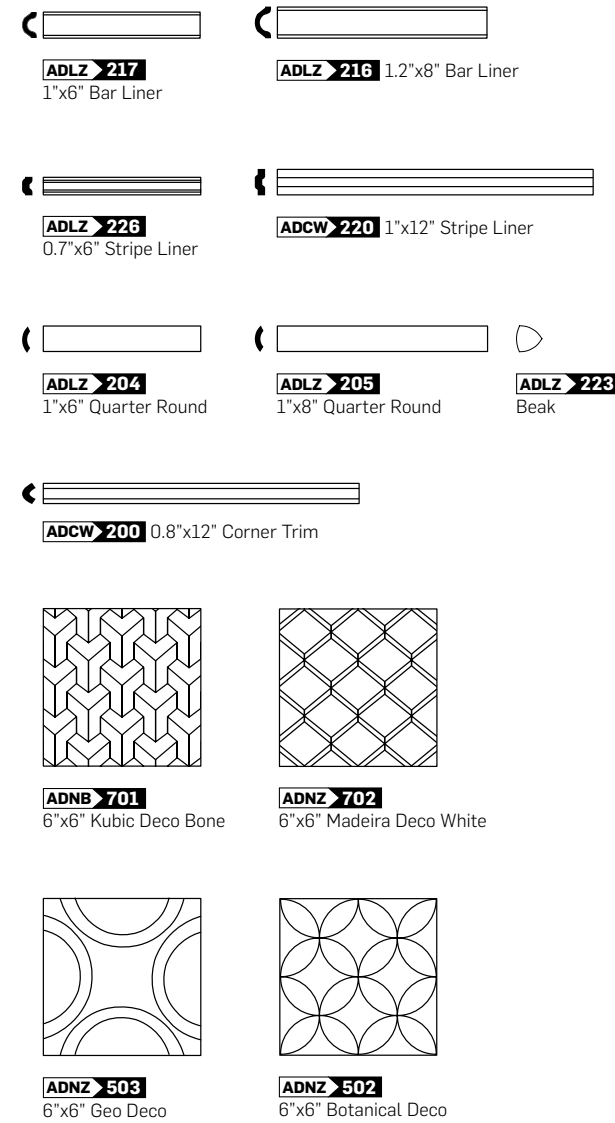

FINISHING TOUCHES

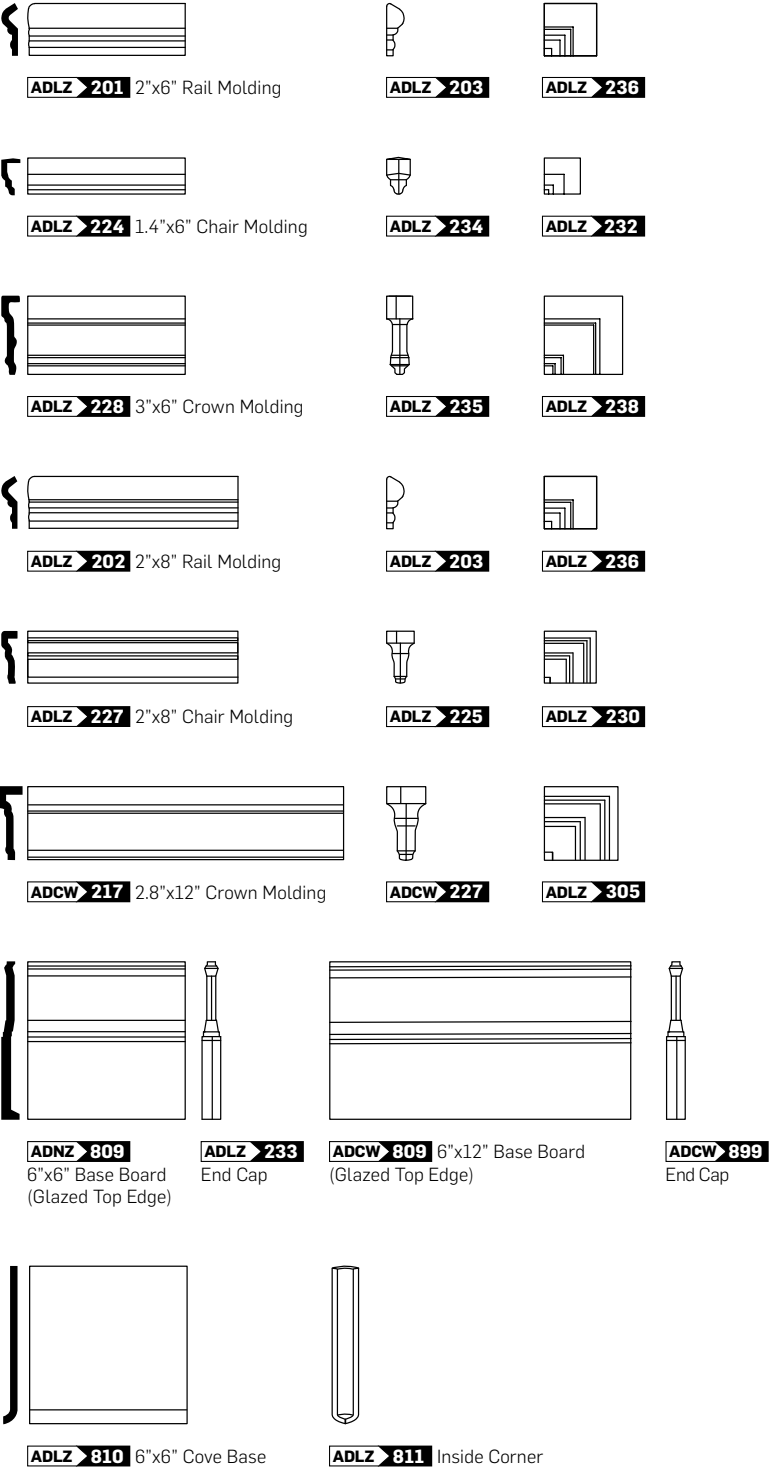

ADNZ White



ADNZ White



ADNZ White



NERI Solid Glaze Glossy Finish

BONE

Find out the product code simply by putting together the color and the item

Example: **ADNB** **836**

FIELD TILES

FLAT

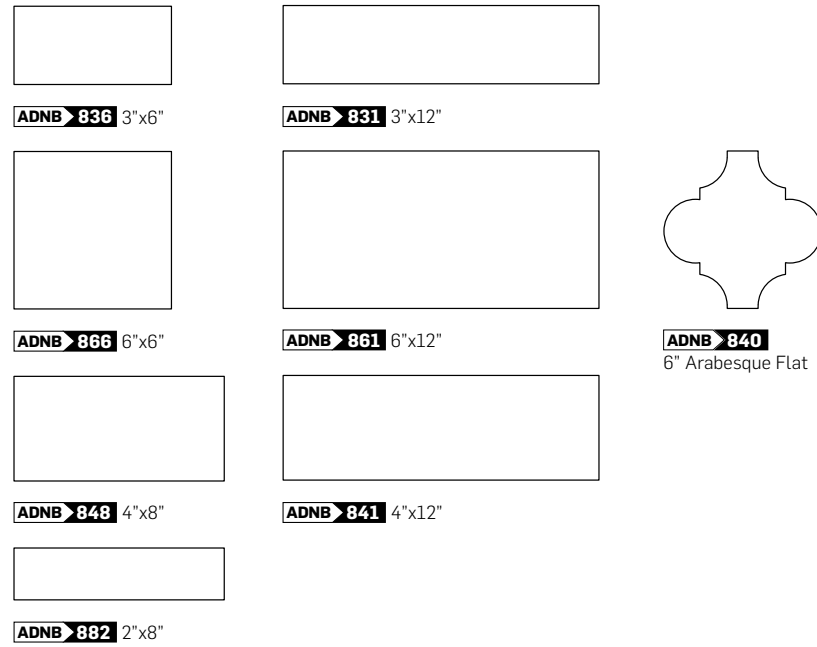

TRIMS

FINISHING EDGES



ADNB 506 FE 0.4"x6"
ADNB 508 FE 0.4"x8"
ADNB 500 FE Corner

BULLNOSES

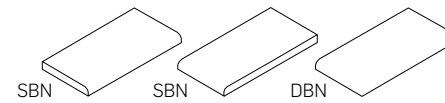

ADNB 805 3"x6" SBN 6"
ADNB 806 3"x6" SBN 3"
ADNB 807 3"x6" DBN Right
ADNB 808 3"x6" DBN Left
ADNB 803 6"x6" SBN
ADNB 804 6"x6" DBN
ADNB 810 4"x8" SBN 4"
ADNB 811 4"x8" SBN 8"
ADNB 812 4"x4" DBN
ADNB 800 2"x2" DBN
ADNB 826 2"x6" SBN 6"
ADNB 828 2"x8" SBN 8"

GLAZED EDGES

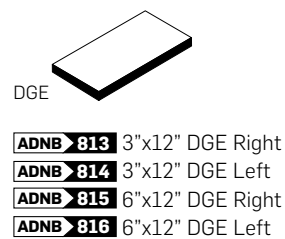

BEVELED

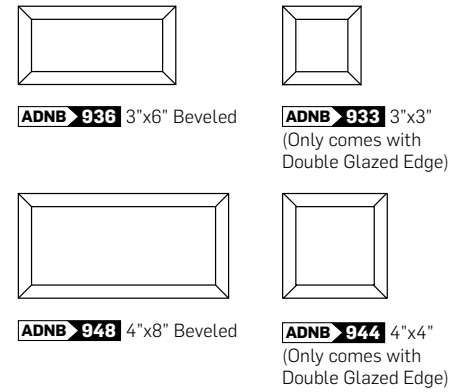

TRIMS

BEVELED GLAZED EDGES

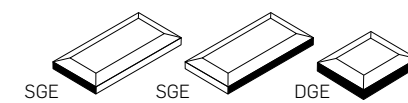

ADNB 907 3"x6" Beveled SGE 3"
ADNB 908 3"x6" Beveled SGE 6"
ADNB 933 3"x3" Beveled DGE
ADNB 911 4"x8" Beveled SGE 4"
ADNB 910 4"x8" Beveled SGE 8"
ADNB 944 4"x4" Beveled DGE

NERI Solid Glaze Glossy Finish

BONE

Find out the product code simply by putting together the color and the item

Example: **ADNB** **836**

DECORATIVE ACCESSORIES

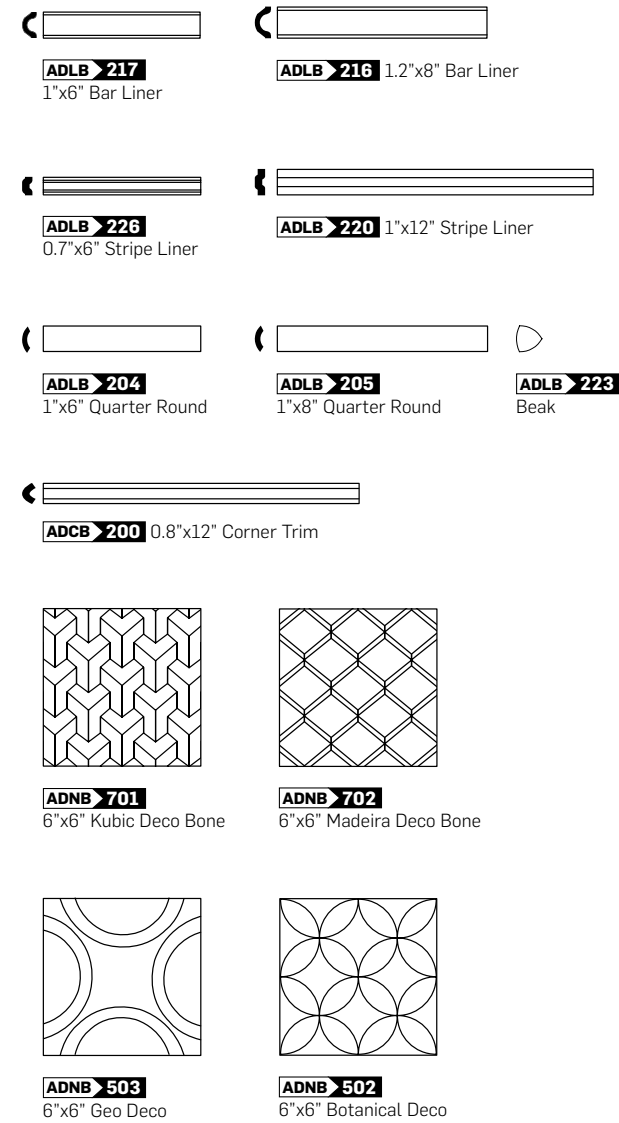

FINISHING TOUCHES

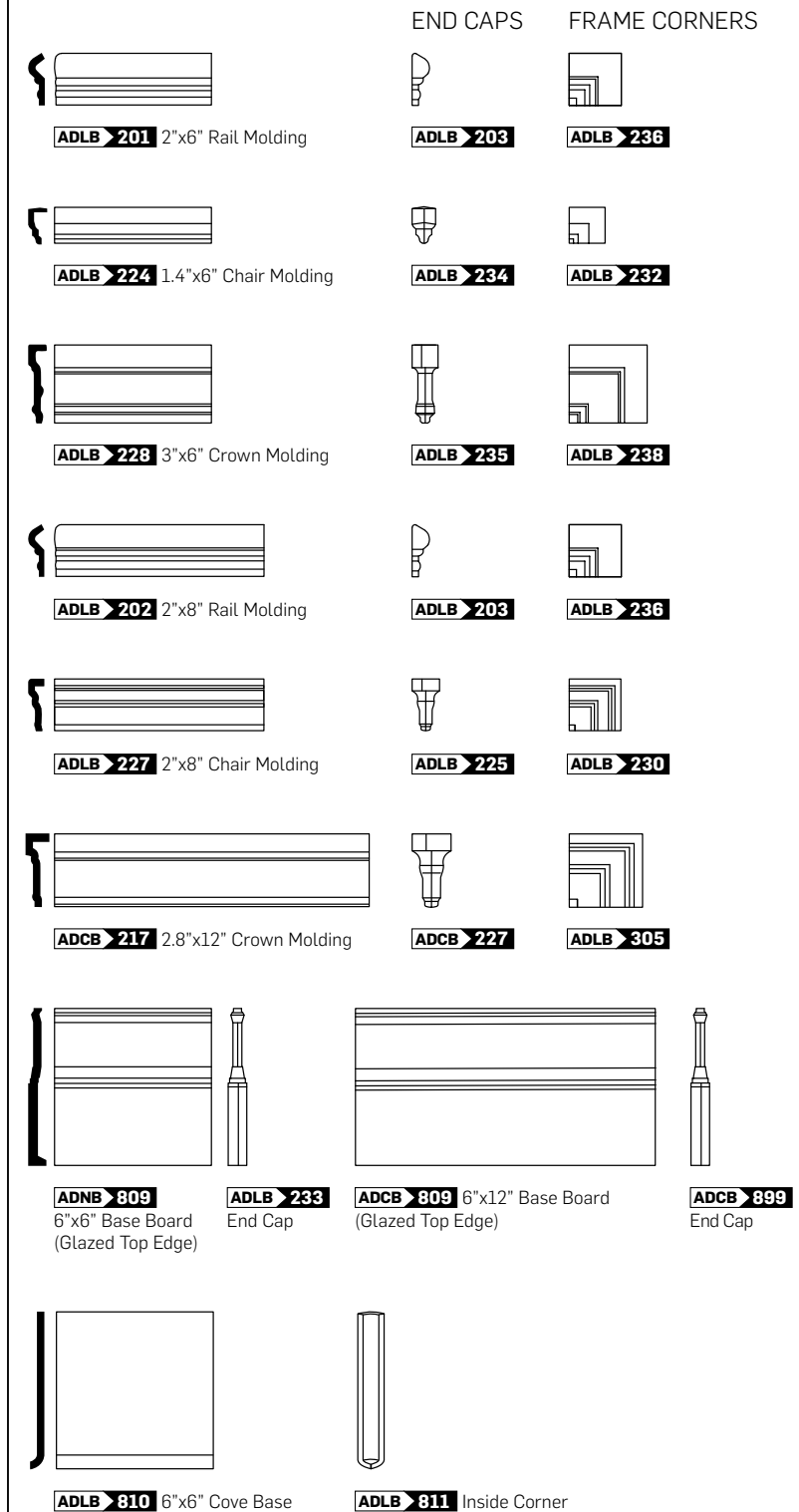

ADNB Bone



ADNB Bone



ADNB Bone



NERI Solid Glaze Glossy Finish

SIERRA SAND

Find out the product code simply by putting together the color and the item

Example: **ADNS 836**

NERI Solid Glaze Glossy Finish

SIERRA SAND

Find out the product code simply by putting together the color and the item

Example: **ADNS 836**

FIELD TILES

FLAT



ADNS 836 3"x6"



ADNS 882 2"x8"

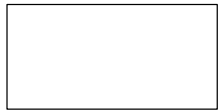

ADNS 848 4"x8"

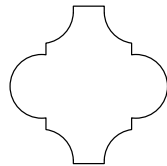

ADNS 840 6" Arabesque Flat

TRIMS

FINISHING EDGES



FE



FE Corner

- ADNS 506** FE 0.4"x6"
- ADNS 508** FE 0.4"x8"
- ADNS 500** FE Corner

BULLNOSES

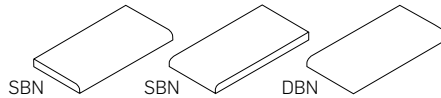

SBN

SBN

DBN

- ADNS 805** 3"x6" SBN 6"
- ADNS 806** 3"x6" SBN 3"
- ADNS 807** 3"x6" DBN Right
- ADNS 808** 3"x6" DBN Left
- ADNS 810** 4"x8" SBN 4"
- ADNS 811** 4"x8" SBN 8"
- ADNS 812** 4"x4" DBN
- ADNS 800** 2"x2" DBN
- ADNS 826** 2"x6" SBN 6"
- ADNS 828** 2"x8" SBN 8"

BEVELED

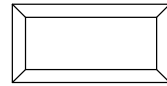

ADNS 936 3"x6" Beveled



ADNS 933 3"x3"
(Only comes with Double Glazed Edge)

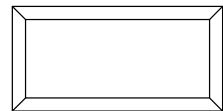

ADNS 948 4"x8" Beveled

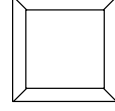

ADNS 944 4"x4"
(Only comes with Double Glazed Edge)

TRIMS

BEVELED GLAZED EDGES

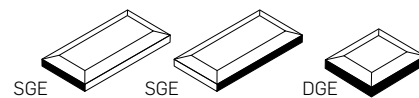

SGE

SGE

DGE

- ADNS 907** 3"x6" Beveled SGE 3"
- ADNS 908** 3"x6" Beveled SGE 6"
- ADNS 933** 3"x3" Beveled DGE
- ADNS 911** 4"x8" Beveled SGE 4"
- ADNS 910** 4"x8" Beveled SGE 8"
- ADNS 944** 4"x4" Beveled DGE

DECORATIVE ACCESSORIES



ADLS 217 1"x6" Bar Liner



ADLS 216 1.2"x8" Bar Liner



ADLS 226 0.7"x6" Stripe Liner

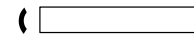

ADLS 204 1"x6" Quarter Round

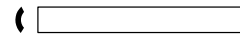

ADLS 205 1"x8" Quarter Round



ADLS 223 Beak

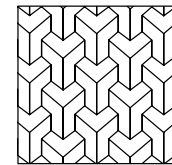

ADNB 701 6"x6" Kubic Deco Bone

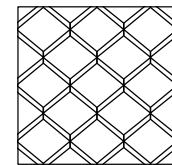

ADNZ 702 6"x6" Madeira Deco White

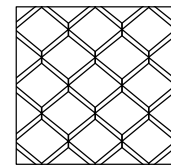

ADNB 702 6"x6" Madeira Deco Bone

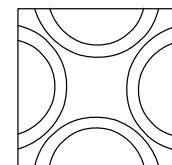

ADNS 503 6"x6" Geo Deco

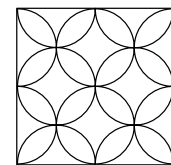

ADNS 502 6"x6" Botanical Deco

FINISHING TOUCHES

END CAPS

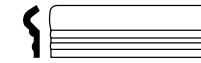

ADLS 201 2"x6" Rail Molding



ADLS 203

FRAME CORNERS



ADLS 236

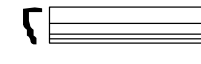

ADLS 224 1.4"x6" Chair Molding



ADLS 234



ADLS 232

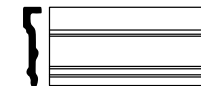

ADLS 228 3"x6" Crown Molding



ADLS 235



ADLS 238

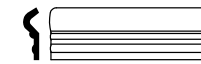

ADLS 202 2"x8" Rail Molding



ADLS 203



ADLS 236



ADLS 227 2"x8" Chair Molding



ADLS 225



ADLS 230

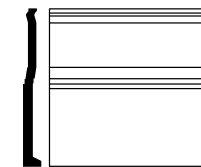

ADNS 809 6"x6" Base Board
(Glazed Top Edge)



ADLS 233

ADNS Sierra Sand



ADNS Sierra Sand



ADNS Sierra Sand



NERI Solid Glaze Glossy Finish

SILVER MIST

Find out the product code simply by putting together the color and the item

Example: **ADNM** **836**

FIELD TILES

FLAT



ADNM 836 3"x6"



ADNM 882 2"x8"



ADNM 848 4"x8"

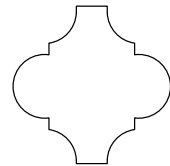

ADNM 840 6" Arabesque Flat

TRIMS

FINISHING EDGES



FE



FE Corner

ADNM 506 FE 0.4"x6"

ADNM 508 FE 0.4"x8"

ADNM 500 FE Corner

BULLNOSES

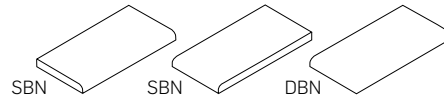

SBN

SBN

DBN

ADNM 805 3"x6" SBN 6"

ADNM 806 3"x6" SBN 3"

ADNM 807 3"x6" DBN Right

ADNM 808 3"x6" DBN Left

ADNM 810 4"x8" SBN 4"

ADNM 811 4"x8" SBN 8"

ADNM 812 4"x4" DBN

ADNM 800 2"x2" DBN

ADNM 826 2"x6" SBN 6"

ADNM 828 2"x8" SBN 8"

BEVELED

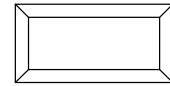

ADNM 936 3"x6" Beveled



ADNM 933 3"x3"
(Only comes with
Double Glazed Edge)

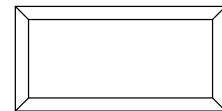

ADNM 948 4"x8" Beveled

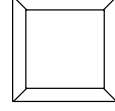

ADNM 944 4"x4"
(Only comes with
Double Glazed Edge)

TRIMS

BEVELED GLAZED EDGES

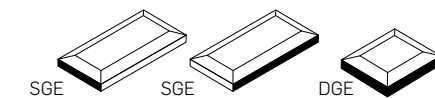

SGE

SGE

DGE

ADNM 907 3"x6" Beveled SGE 3"

ADNM 908 3"x6" Beveled SGE 6"

ADNM 933 3"x3" Beveled DGE

ADNM 911 4"x8" Beveled SGE 4"

ADNM 910 4"x8" Beveled SGE 8"

ADNM 944 4"x4" Beveled DGE

NERI Solid Glaze Glossy Finish

SILVER MIST

Find out the product code simply by putting together the color and the item

Example: **ADNM** **836**

DECORATIVE ACCESSORIES

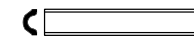

ADLM 217 1"x6" Bar Liner



ADLM 216 1.2"x8" Bar Liner



ADLM 226 0.7"x6" Stripe Liner

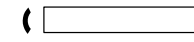

ADLM 204
1"x6" Quarter Round

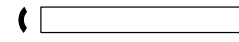

ADLM 205
1"x8" Quarter Round



ADLM 223
Beak

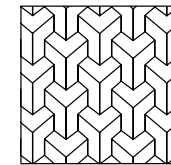

ADNB 701 6"x6" Kubic Deco Bone

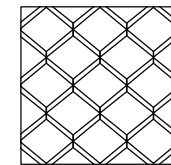

ADNZ 702
6"x6" Madeira Deco White

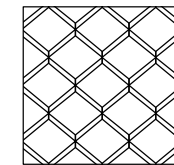

ADNB 702
6"x6" Madeira Deco Bone

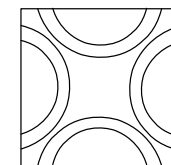

ADNM 503 6"x6" Geo Deco

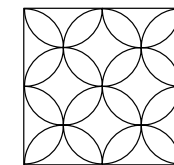

ADNM 502 6"x6" Botanical Deco

FINISHING TOUCHES

END CAPS

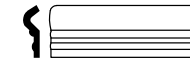

ADLM 201 2"x6" Rail Molding



ADLM 203

FRAME CORNERS



ADLM 236

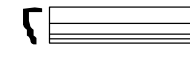

ADLM 224 1.4"x6" Chair Molding



ADLM 234



ADLM 232

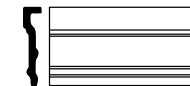

ADLM 228 3"x6" Crown Molding



ADLM 235



ADLM 238

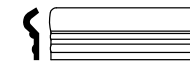

ADLM 202 2"x8" Rail Molding



ADLM 203



ADLM 236



ADLM 227 2"x8" Chair Molding



ADLM 225



ADLM 230

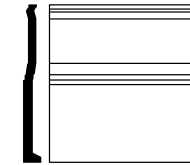

ADNM 809 6"x6" Base Board
(Glazed Top Edge)

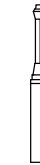

ADLM 233

ADNM Silver Mist



ADNM Silver Mist



ADNM Silver Mist

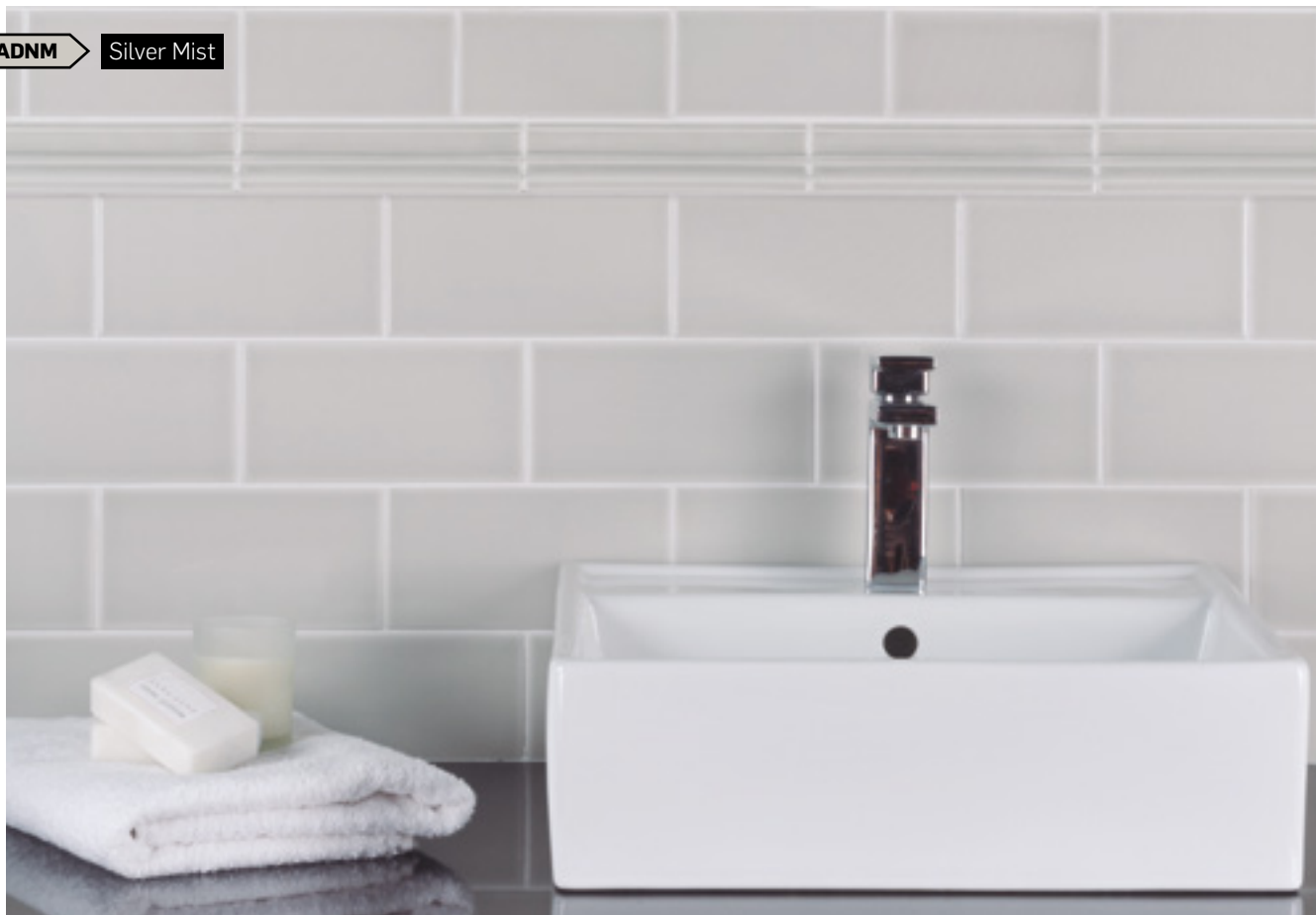

NERI Solid Glaze Glossy Finish

BLACK

FIELD TILES

FLAT



ADNK 836 3"x6"

TRIMS

FINISHING EDGES



ADNK 506 FE 0.4"x6"
ADNK 500 FE Corner

BULLNOSES

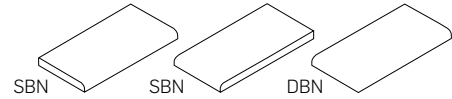

ADNK 805 3"x6" SBN 6"
ADNK 806 3"x6" SBN 3"
ADNK 807 3"x6" DBN Right
ADNK 808 3"x6" DBN Left

BEVELED

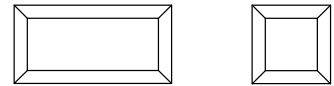

ADNK 936 3"x6" Beveled ADNK 933 3"x3"
(Only comes with Double Glazed Edge)

TRIMS

BEVELED GLAZED EDGES

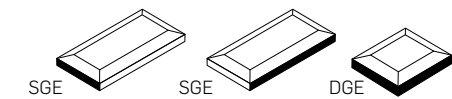

ADNK 907 3"x6" Beveled SGE 3"
ADNK 908 3"x6" Beveled SGE 6"
ADNK 933 3"x3" Beveled DGE

Find out the product code simply by putting together the color and the item

Example: **ADNK** **836**

DECORATIVE ACCESSORIES

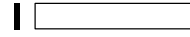

ADLK 213 1"x6" Flat Liner



ADLK 226 0.7"x6" Stripe Liner

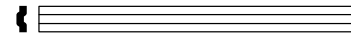

ADCK 220 1"x12" Stripe Liner

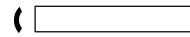

ADLK 204 1"x6" Quarter Round



ADLK 223 Beak

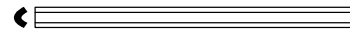

ADCK 200 0.8"x12" Corner Trim

FINISHING TOUCHES

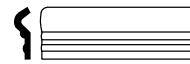

ADLK 201 2"x6" Rail Molding

END CAPS



ADLK 203

FRAME CORNERS



ADLK 236

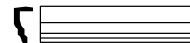

ADLK 224 1.4"x6" Chair Molding



ADLK 234



ADLK 232

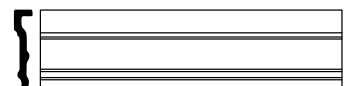

ADCK 217 2.8"x12" Crown Molding



ADLK 227



ADLK 305



ADLK 227 2"x8" Chair Molding



ADLK 225



ADLK 230

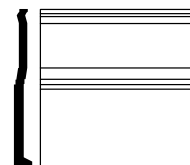

ADNK 809 6"x6" Base Board
(Glazed Top Edge)



ADNK 233 End Cap



ADCK 809 6"x12" Base Board
(Glazed Top Edge)



ADCK 899 End Cap

ADNK Black



STUDIO Translucent Glaze

Glossy Finish - Slightly Undulated Surface

Find out the product code simply by putting together the color and the item

Example: **ADSTW** **836**

AVAILABLE COLORS

- Snow Cap **ADSTW** Bamboo **ADSTB** Ice Blue **ADSTI** Fern **ADSTF** Almond **ADSTA** Eucalyptus **ADSTE**
 Silver Sands **ADSTS** Graystone **ADSTG** Timberline **ADSTT** Volcanico **ADSTV**

FIELD TILES

UNDULATED

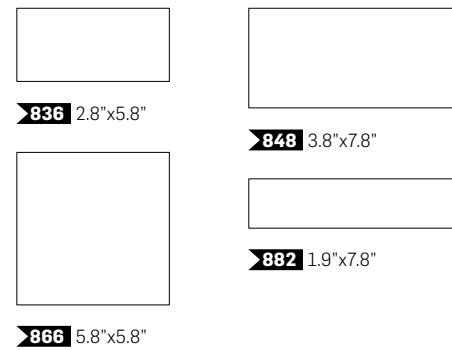

FRAMED

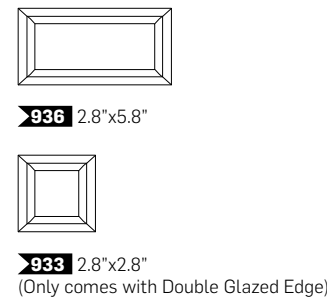

BEVELED

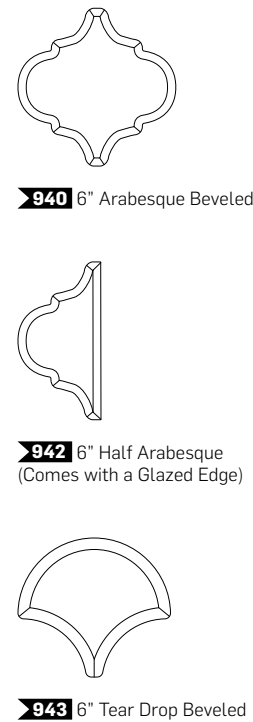

TRIMS

FINISHING EDGES

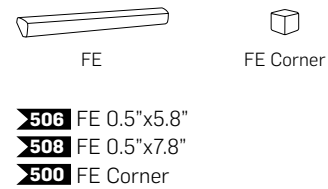

GLAZED EDGES

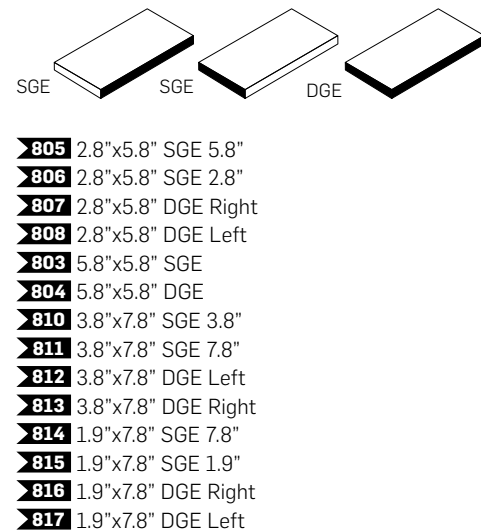

TRIMS

FRAMED GLAZED EDGES

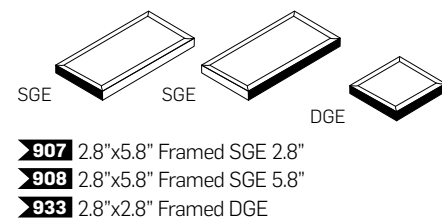

TRIMS

BEVELED GLAZED EDGES



STUDIO Translucent Glaze

Glossy Finish - Slightly Undulated Surface

Find out the product code simply by putting together the color and the item

Example: **ADSTW** **836**

AVAILABLE COLORS

- Snow Cap **ADSTW** Bamboo **ADSTB** Ice Blue **ADSTI** Fern **ADSTF** Almond **ADSTA** Eucalyptus **ADSTE**
 Silver Sands **ADSTS** Graystone **ADSTG** Timberline **ADSTT** Volcanico **ADSTV**

DECORATIVE ACCESSORIES

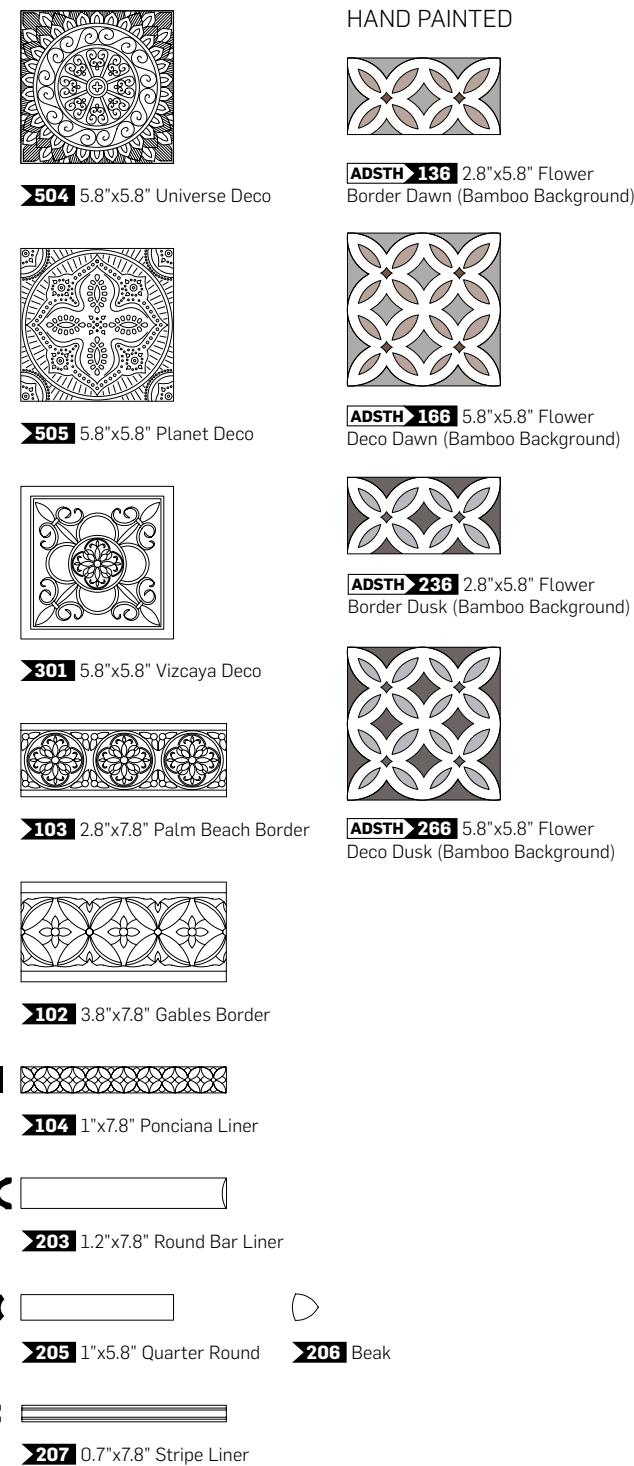

FINISHING TOUCHES

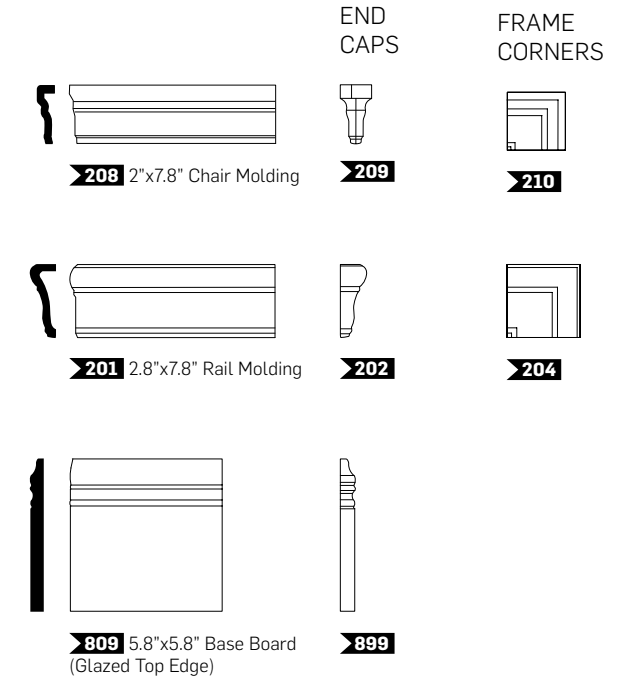

ADSTW Snow Cap



ADSTI Ice Blue



ADSTB Bamboo



ADSTF Fern



ADSTA Almond



ADSTS Silver Sands



ADSTE Eucalyptus



ADSTG Graystone



ADSTT Timberline



ADSTV Volcanico



ADSTH 266



RIVIERA Multi Tone Glaze

Glossy Finish

Find out the product code simply by putting together the color and the item

Example: **ADRLI** **844**

AVAILABLE COLORS

- Lido White **ADRLI** Niza Blue **ADRNI** Altea Blue **ADRAL** Santorini Blue **ADRSA** Monaco Red **ADRMO**
 Cadaques Gray **ADRCA** Mundaka Gray **ADMU** Rodas Blue **ADRRO** Rimini Green **ADRR** Malvarrosa **ADRMA**

FIELD TILES

FLAT

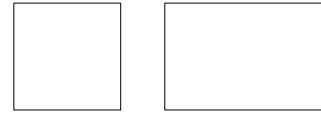

844 4"x4" **846** 4"x6"

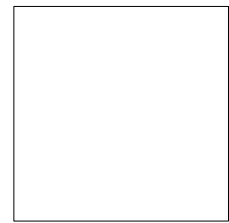

888 8"x8"

TRIMS

FINISHING EDGES



FE

501 FE 0.4"x8"
500 FE Corner



FE Corner

DECORATIVE ACCESSORIES



206 0.7"x8" Stripe Liner (One Overglazed Edge)



204 1"x8" Quarter Round **205** Beak

FINISHING TOUCHES

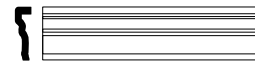

201 2"x8" Chair Molding

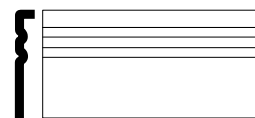

809 4"x8" Base Board
 (Glazed Top Edge)

END CAPS



202



810

FRAME CORNERS



203

ADRLI Lido White



ADRNI

Niza Blue



ADRAL

Altea Blue

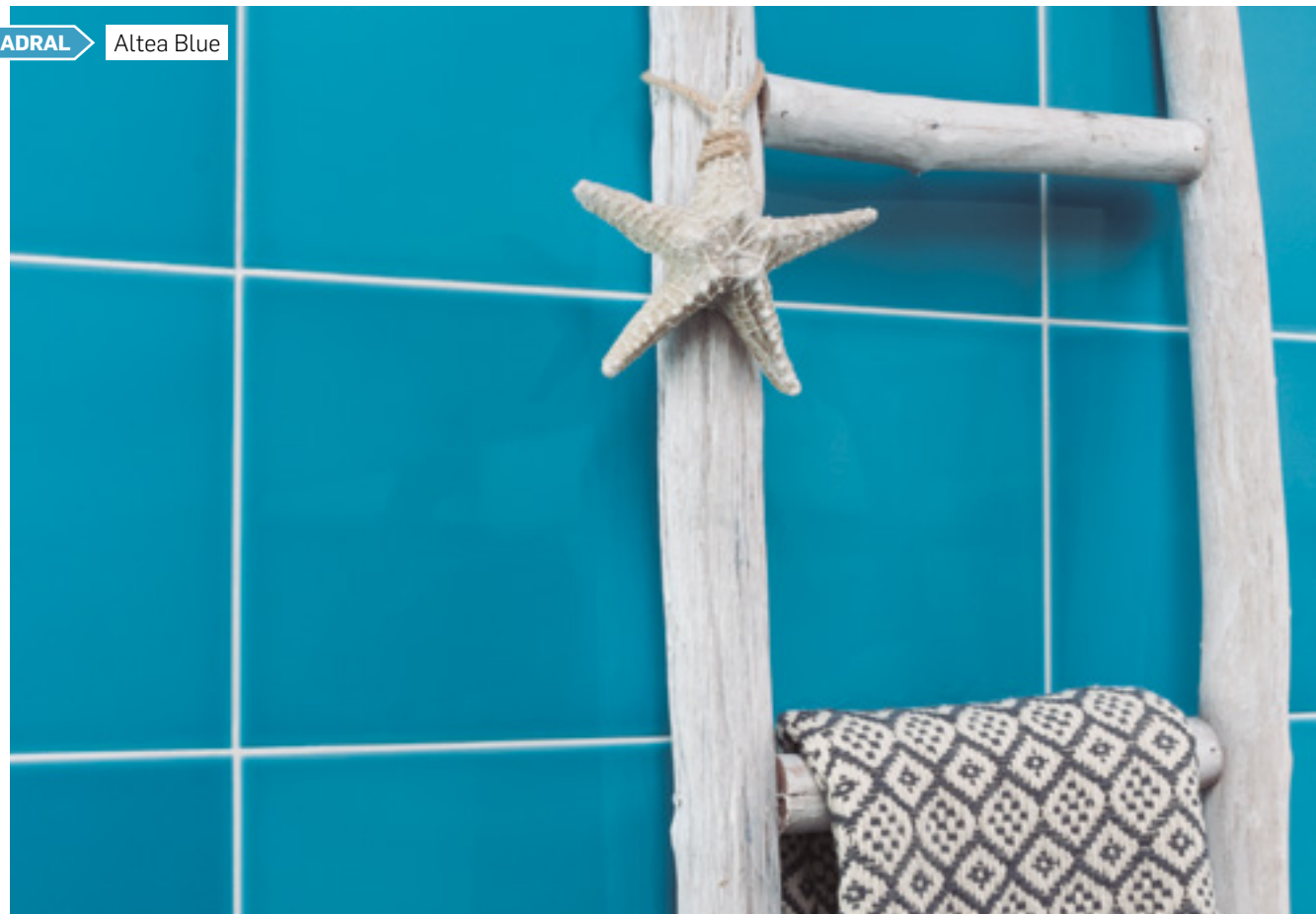

ADRSA

Santorini Blue



ADRM Monaco Red



ADRCA Cadaques Gray



ADRMU Mundaka Gray



ADRR0 Rodas Blue





HABITAT Multi Tone Glaze

Glossy Finish - Undulated Surface

Find out the product code simply by putting together the color and the item

Example: **ADHGC** **825**

AVAILABLE COLORS

Cloud **ADHGC** Alabaster **ADHGA** River Blue **ADHGR** Leaf **ADHGL** Pewter **ADHGP** Graphite **ADHGG**

FIELD TILES

UNDULATED



825 2.5"x5.1"



821 2.5"x10.3"



844 5.1"x5.1"

TRIMS

FINISHING EDGES



501 FE 0.55"x10.3"

500 FE Corner



FE Corner

DECORATIVE ACCESSORIES



206 0.6"x10.3" Liner (One Overglazed Edge)



204 1"x10.3" Quarter Round



205 Beak

FINISHING TOUCHES



201 2"x10.3" Molding

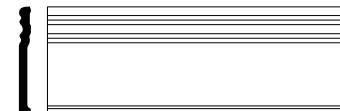

809 4"x10.3" Base Board (Glazed Top Edge)

END CAPS



202



810

FRAME CORNERS



203

HABITAT Multi Tone Glaze

Matte Finish - Undulated Surface

Find out the product code simply by putting together the color and the item

Example: **ADHMC** **825**

AVAILABLE COLORS

Cloud **ADHMC** Alabaster **ADHMA** River Blue **ADHMR** Leaf **ADHML** Pewter **ADHMP** Graphite **ADHMG**

FIELD TILES

UNDULATED



825 2.5"x5.1"



821 2.5"x10.3"

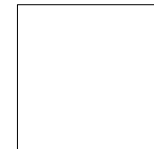

844 5.1"x5.1"

TRIMS

FINISHING EDGES

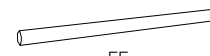

501 FE 0.55"x10.3"

500 FE Corner



FE Corner

DECORATIVE ACCESSORIES



206 0.6"x10.3" Liner (One Overglazed Edge)



204 1"x10.3" Quarter Round



205 Beak

FINISHING TOUCHES



201 2"x10.3" Molding

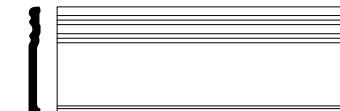

809 4"x10.3" Base Board (Glazed Top Edge)

END CAPS



202



810

FRAME CORNERS



203

ADHGC Cloud Glossy



ADHGA Alabaster Glossy

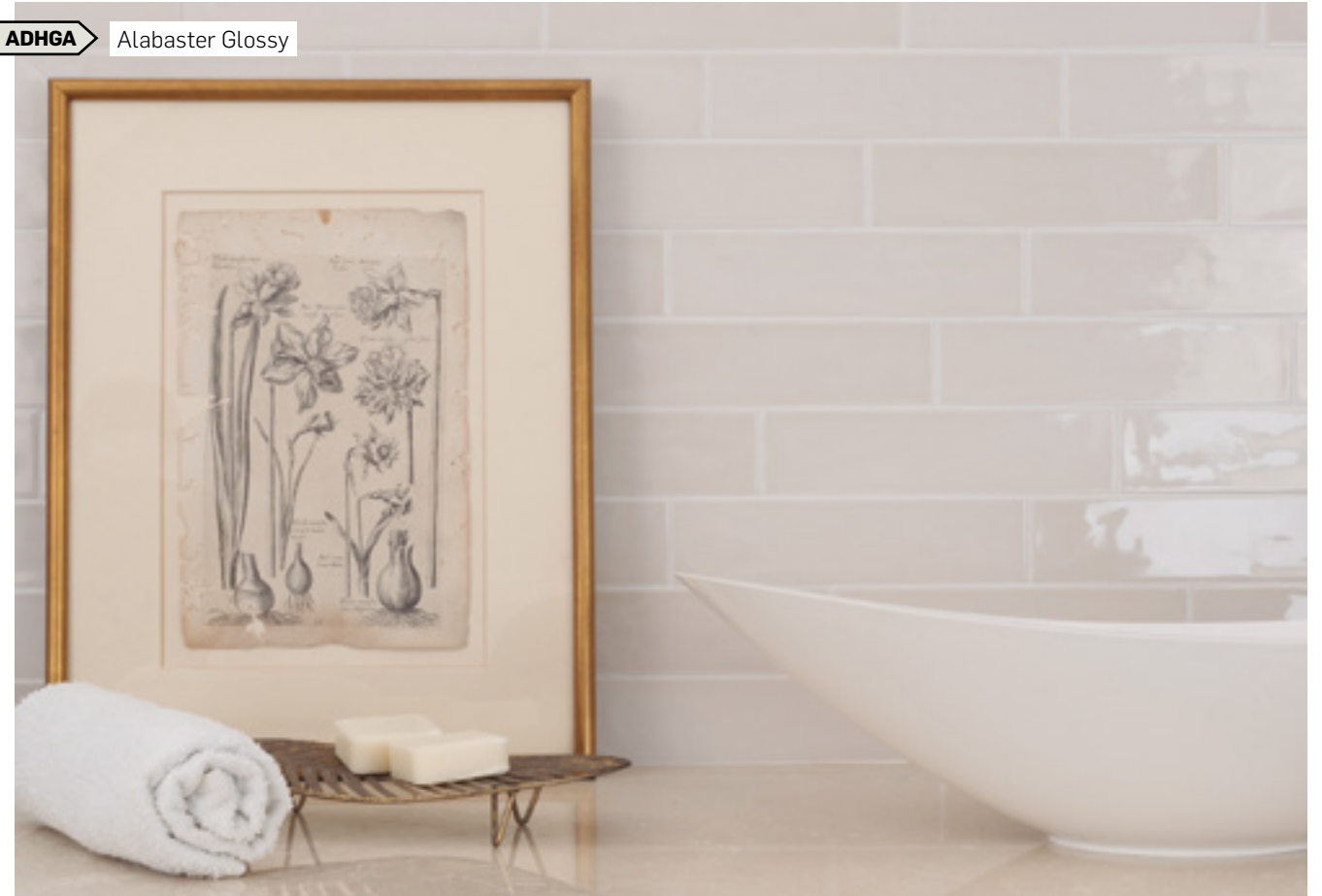

ADHGR River Blue Glossy



ADHGL Leaf Glossy



ADHGG Graphite Glossy



ADHGP Pewter Glossy



ADHMC Cloud Matte

ADHMR River Blue Matte

ADHML Leaf Matte

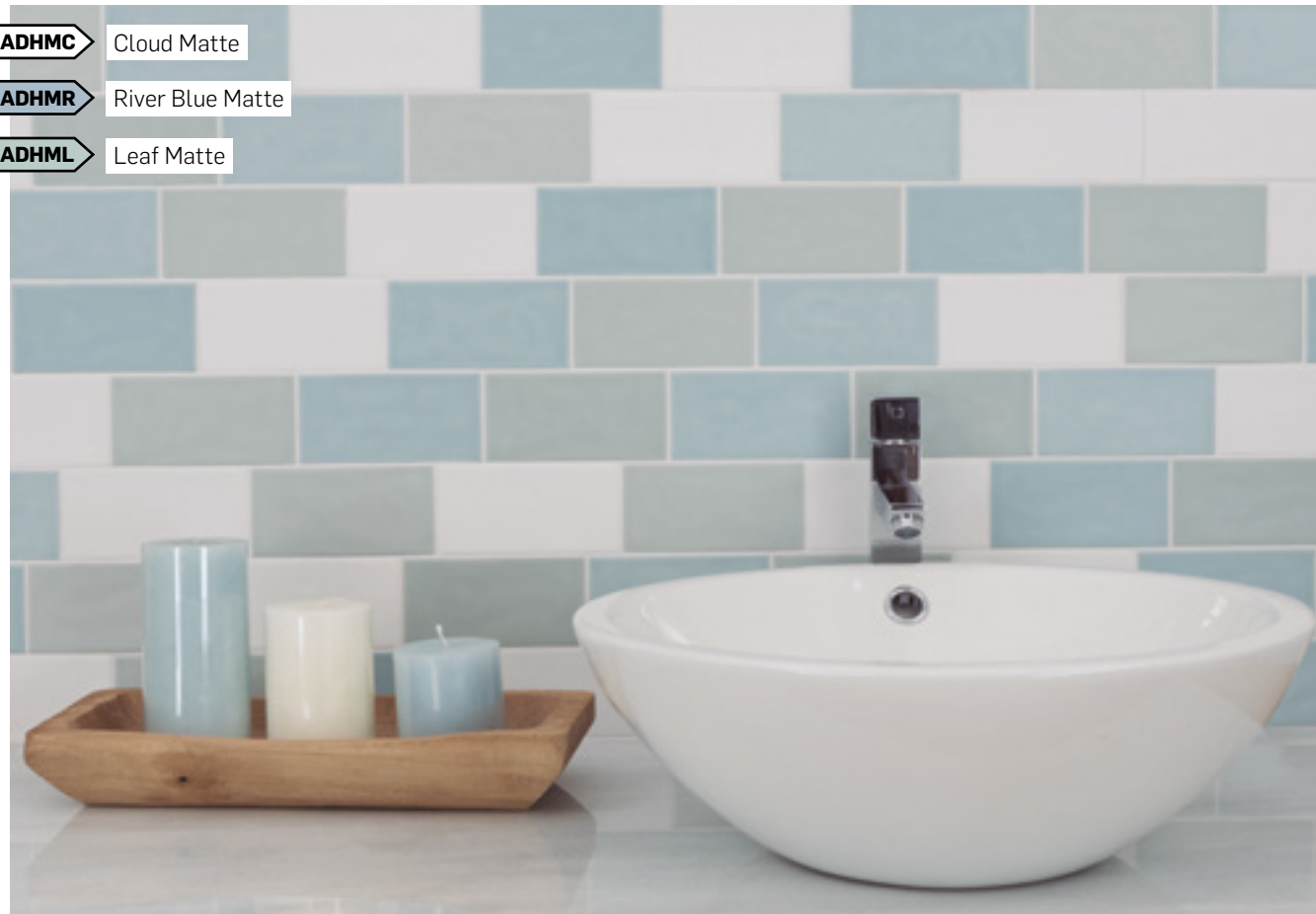

ADHMR River Blue Matte



ADHMA Alabaster Matte



ADHML Leaf Matte



ADHMP Pewter Matte



ADHMG Graphite Matte



EARTH Matte Crackle

Semi-Matte Finish

AVAILABLE COLORS

Navajo White **ADEW** Fawn **ADEF** Ash Gray **ADEG** Morning Sky **ADEM**

Find out the product code simply by putting together the color and the item

Example: **ADEW** **836**

FIELD TILES

UNDULATED



836 3"x6"



831 3"x12"

TEXTURED



836T 3"x6" Textured

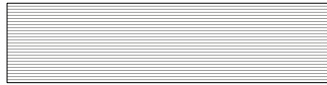

831T 3"x12" Textured

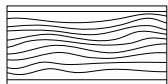

101 3"x6" Waves

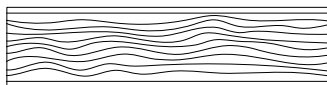

102 3"x12" Waves

TRIMS

FINISHING EDGES



FE



FE Corner

508 FE 0.5"x6"

512 FE 0.6"x12"

500 FE Corner 6"

501 FE Corner 12"

DECORATIVE ACCESSORIES

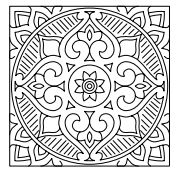

502 6"x6" Energy Deco

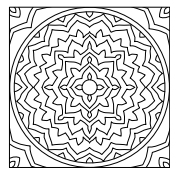

503 6"x6" Cosmos Deco



206 1"x6" Bar Liner



207 1"x12" Bar Liner

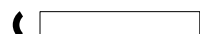

204 1"x6" Quarter Round



205 Beak

FINISHING TOUCHES

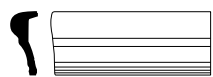

200 2.4"x6" Molding

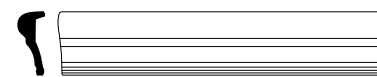

201 2.4"x12" Molding



202



203



809 5.1"x6" Base Board
(Glazed Top Edge)

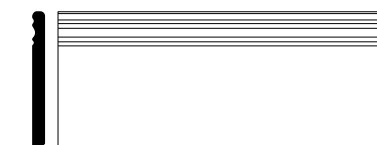

810 5.1"x12" Base Board
(Glazed Top Edge)

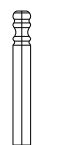

899

ADEW Navajo White



ADEG Ash Gray



ADEF Fawn



ADEM Morning Sky



OCEAN Micro Crackle

Glossy Finish - Slightly Undulated Surface

Find out the product code simply by putting together the color and the item

Example: **ADOW** **836**

AVAILABLE COLORS

Whitecaps **ADOW** Sand Dollar **ADOS** Surf Gray **ADOG** Top Sail **ADOT**

FIELD TILES

UNDULATED



836 3"x6"



839 3"x9"

TRIMS

FINISHING EDGES



FE



FE Corner

506 FE 0.4"x6"

509 FE 0.4"x9"

500 FE Corner

GLAZED EDGES

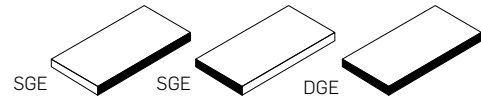

801 3"x6" SGE 6"

802 3"x6" SGE 3"

803 3"x6" DGE Right

804 3"x6" DGE Left

805 3"x9" SGE 9"

806 3"x9" SGE 3"

807 3"x9" DGE Right

808 3"x9" DGE Left

DECORATIVE ACCESSORIES

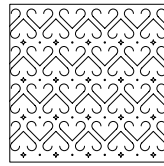

501 6"x6" Persian Deco

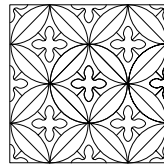

502 6"x6" Caspian Deco



207 0.8"x6" Stripe Liner

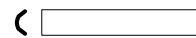

208 1"x6" Bar Liner

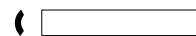

209 1"x6" Quarter Round



210 Beak

FINISHING TOUCHES



201 1.2"x6" Chair Molding

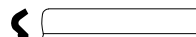

204 2"x6" Rail Molding

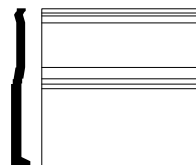

809 6"x6" Base Board
(Glazed Top Edge)

END CAPS



202



205



810

FRAME CORNERS



203



206

ADOW Whitecaps



ADOS Sand Dollar



ADOT Top Sail



ADOG Surf Gray



HAMPTON Classic Crackle Glossy Finish

Find out the product code simply by putting together the color and the item

Example: **ADHWH** **836**

AVAILABLE COLORS

White **ADHWH** Bone **ADHBQ** Cadet Gray **ADHCG** Stratus **ADHSG** Stellar Blue **ADHSB**

FIELD TILES

FLAT



836 3"x6"

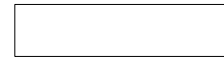

882 2"x8"



848 4"x8"

TRIMS

FINISHING EDGES



FE



FE Corner

506 FE 0.4"x6"

508 FE 0.4"x8"

500 FE Corner

BULLNOSES



SBN

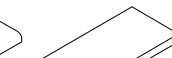

SBN

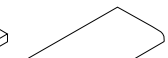

DBN

805 3"x6" SBN 6"

806 3"x6" SBN 3"

807 3"x6" DBN Right

808 3"x6" DBN Left

810 4"x8" SBN 4"

811 4"x8" SBN 8"

812 4"x4" DBN

822 2"x2" DBN

826 2"x6" SBN 6"

828 2"x8" SBN 8"

BEVELED

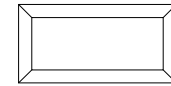

936 3"x6" Beveled



933 3"x3" Beveled (Only comes with Double Glazed Edge)

TRIMS

BEVELED GLAZED EDGES

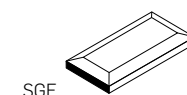

SGE

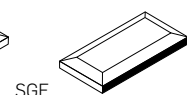

SGE



DGE

906 3"x6" Beveled SGE 3"

905 3"x6" Beveled SGE 6"

933 3"x3" Beveled DGE

HAMPTON Classic Crackle Glossy Finish

Find out the product code simply by putting together the color and the item

Example: **ADHWH** **836**

AVAILABLE COLORS

White **ADHWH** Bone **ADHBQ** Cadet Gray **ADHCG** Stratus **ADHSG** Stellar Blue **ADHSB**

DECORATIVE ACCESSORIES

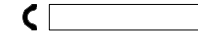

207 1"x6" Bar Liner



220 0.7"x6" Stripe Liner

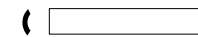

203 1"x6" Quarter Round



216 Beak

FINISHING TOUCHES

END CAPS



214



228



227



302



229

FRAME CORNERS



304



300



306



303

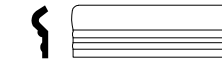

201 2"x6" Rail Molding

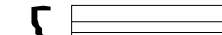

219 1.4"x6" Chair Molding

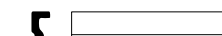

217 3"x6" Crown Molding

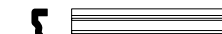

301 2"x8" Chair Molding



809 6"x6" Base Board (Glazed Top Edge)

ADHWH White



ADHBQ Bone



ADHCG Cadet Gray



ADHSG Stratus



ADHSB Stellar Blue



DIAMONDS Dimensional Field

Glossy Finish

AVAILABLE COLORS

White **ADNZ** Bone **ADNB**

Find out the product code simply by putting together the color and the item

Example: **ADNZ** **684**

FLAT

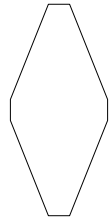

684 8"x4" Flat

PILLOW



884 8"x4" Pillow

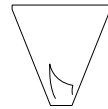

881 4"x4" Half Pillow

PILLOW SILVER

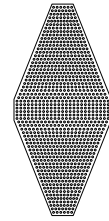

ADMS 884 8"x4" Pillow Silver

White and Bone Diamonds are color coordinated with the Neri collection.

ACCENT DOTS 3/4"x3/4"

Ceramic Flat



ADNZ 6840
Accent Dot White



ADNB 6840
Accent Dot Bone



ADNSS 6840
Accent Dot Sierra Sand



ADNSM 6840
Accent Dot Silvert Mist



ADNS 6840
Accent Dot Silver



ADNG 6840
Accent Dot Gold



ADNK 6840
Accent Dot Black

White, Bone, Sierra Sand, Silver Mist and Black Flat Dots are color coordinated with the Neri collection.

ACCENT DOTS 3/4"x3/4"

Ceramic Sphere



ADNZ 6842
Accent Dot White



ADNB 6842
Accent Dot Bone



ADNSS 6842
Accent Dot Sierra Sand



ADNSM 6842
Accent Dot Silvert Mist



ADNS 6842
Accent Dot Silver



ADNG 6842
Accent Dot Gold



ADNK 6842
Accent Dot Black



ADNR 6842
Accent Dot Red

White, Bone, Sierra Sand, Silver Mist and Black Sphere Dots are color coordinated with the Neri collection.



MOSAIC Glazed Porcelain Mosaics
Glossy & Matte Finish

PENNY ROUNDS 3/4" | Mesh Mounted 12.38"x11.50"

GLOSSY FINISH

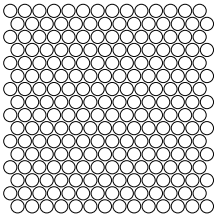

ADPZ 700
 Penny Rounds White

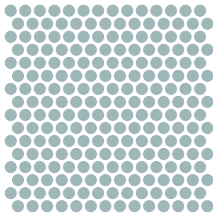

ADPB 700
 Penny Rounds Light Blue

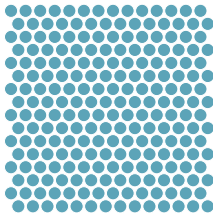

ADPD 700
 Penny Rounds Denim

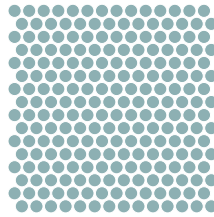

ADPTE 700
 Penny Rounds Teal

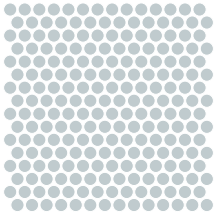

ADPSA 700
 Penny Rounds Sage

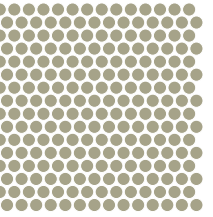

ADPSS 700
 Penny Rounds Light Sandstone

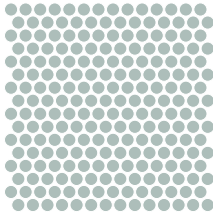

ADPG 700
 Penny Rounds Light Gray

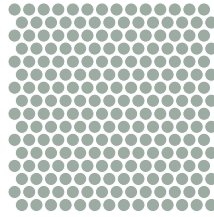

ADPT 700
 Penny Rounds Taupe

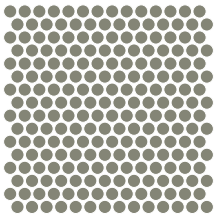

ADPS 700
 Penny Rounds Light Smoke

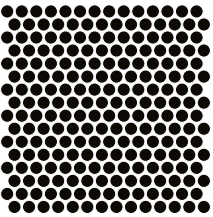

ADPK 700
 Penny Rounds Black

MATTE FINISH

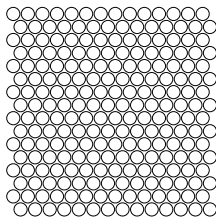

ADPZM 700
 Penny Rounds Matte White

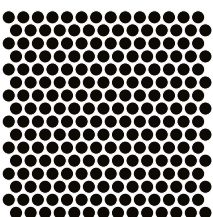

ADPKM 700
 Penny Rounds Matte Black



MOSAIC Glazed Porcelain Mosaics
Glossy & Matte Finish

HEXAGONS 1" | Mesh Mounted 11.97"x11.69"

GLOSSY FINISH

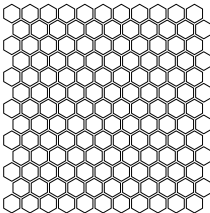

ADMZ 600
Hexagons White

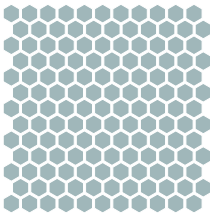

ADMB 600
Hexagons Light Blue



ADMD 600
Hexagons Denim

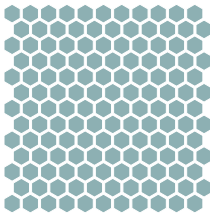

ADMTE 600
Hexagons Teal

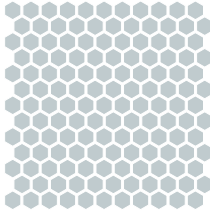

ADMSA 600
Hexagons Sage

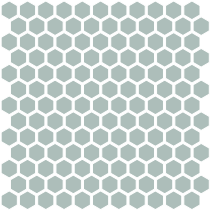

ADMG 600
Hexagons Light Gray

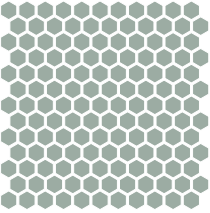

ADMT 600
Hexagons Taupe

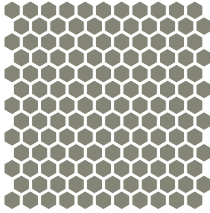

ADMS 600
Hexagons Light Smoke

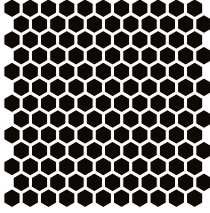

ADMK 600
Hexagons Black

MATTE FINISH

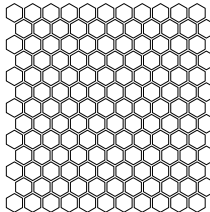

ADMZM 600
Hexagons Matte White

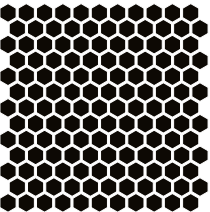

ADMKM 600
Hexagons Matte Black



FLOOR Glazed Porcelain Tiles (39% Recycled)

Semi-Matte Finish

SQUARE 7.4"x7.4"



ADFW 500 Square White

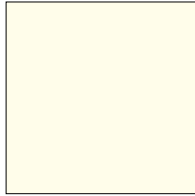

ADFB 500 Square Bone



ADFL 500 Square Light Gray



ADFD 500 Square Dark Gray



ADFA 500 Square Azure



ADFK 500 Square Black

PICKETS 1.5"x9"



ADFW 700 Picket White

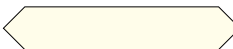

ADFB 700 Picket Bone



ADFL 700 Picket Light Gray



ADFD 700 Picket Dark Gray



ADFM 700 Picket Wood



ADFA 700 Picket Azure



ADFK 700 Picket Black



ADFA Azure
ADFW White



ADFB Bone
ADFM Wood

FLOOR Glazed Porcelain Tiles (39% Recycled)
Semi-Matte Finish

HEX 8"x9"

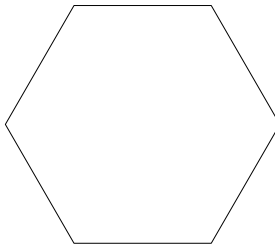

ADFW 300 Hex White

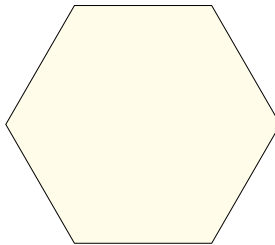

ADFB 300 Hex Bone

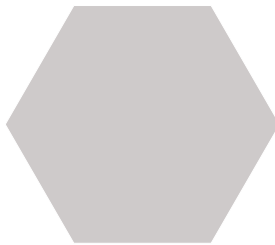

ADFL 300 Hex Light Gray

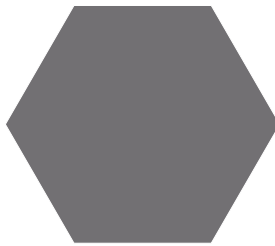

ADFD 300 Hex Dark Gray

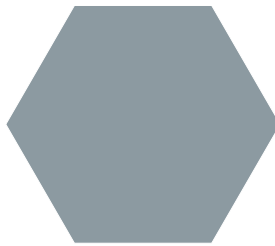

ADFA 300 Hex Azure

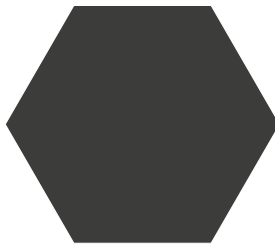

ADFK 300 Hex Black

HEX DECO 8"x9"

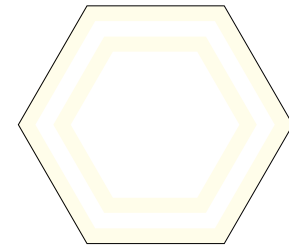

ADFB 301 Hex Deco Bone



ADFL 301 Hex Deco Light Gray



ADFD 301 Hex Deco Dark Gray



ADFA 301 Hex Deco Azure



ADFK 301 Hex Deco Black



FLOOR Glass Floor Tiles (98% Recycled)
Semi-Matte Finish

VINTAGE HEX 1"

MESH MOUNTED 11.85"x11.41"

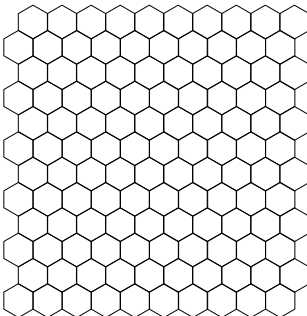

ADGL 946 Vintage Hex 1" White

MESH MOUNTED 11.85"x9.13"

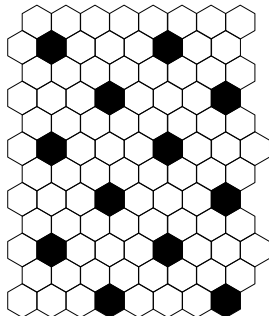

ADGL 945 Vintage Hex 1" Flower

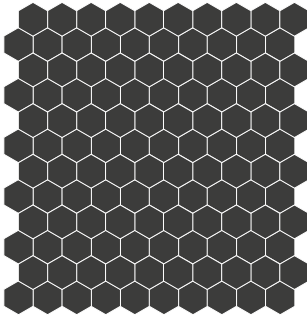

ADGL 947 Vintage Hex 1" Black



ADGL 945

ADEX USA CUSTOM SHOP CERAMIC TILE CRAFTED COUTURE

Go to www.adexusa.com/custom-shop/ to customize your own ceramics, you will be able to choose the color, size and finish desired.

1

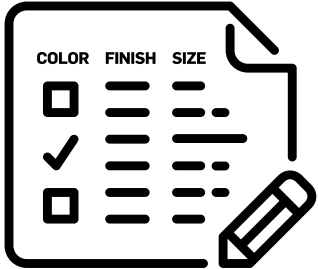

Specify size, color and finish via Pantone or control sample

2



Samples sent via UPS for approval

3

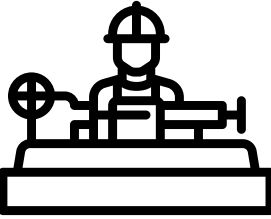

APPROXIMATELY
2-3 WEEKS TO PRODUCE

Once approved and deposit received, production begins

4

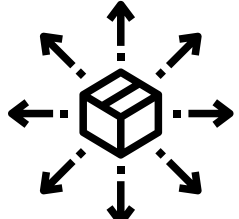

4-6 WEEKS TRANSIT

Material can be shipped direct to a job site or to an Adex USA distribution center

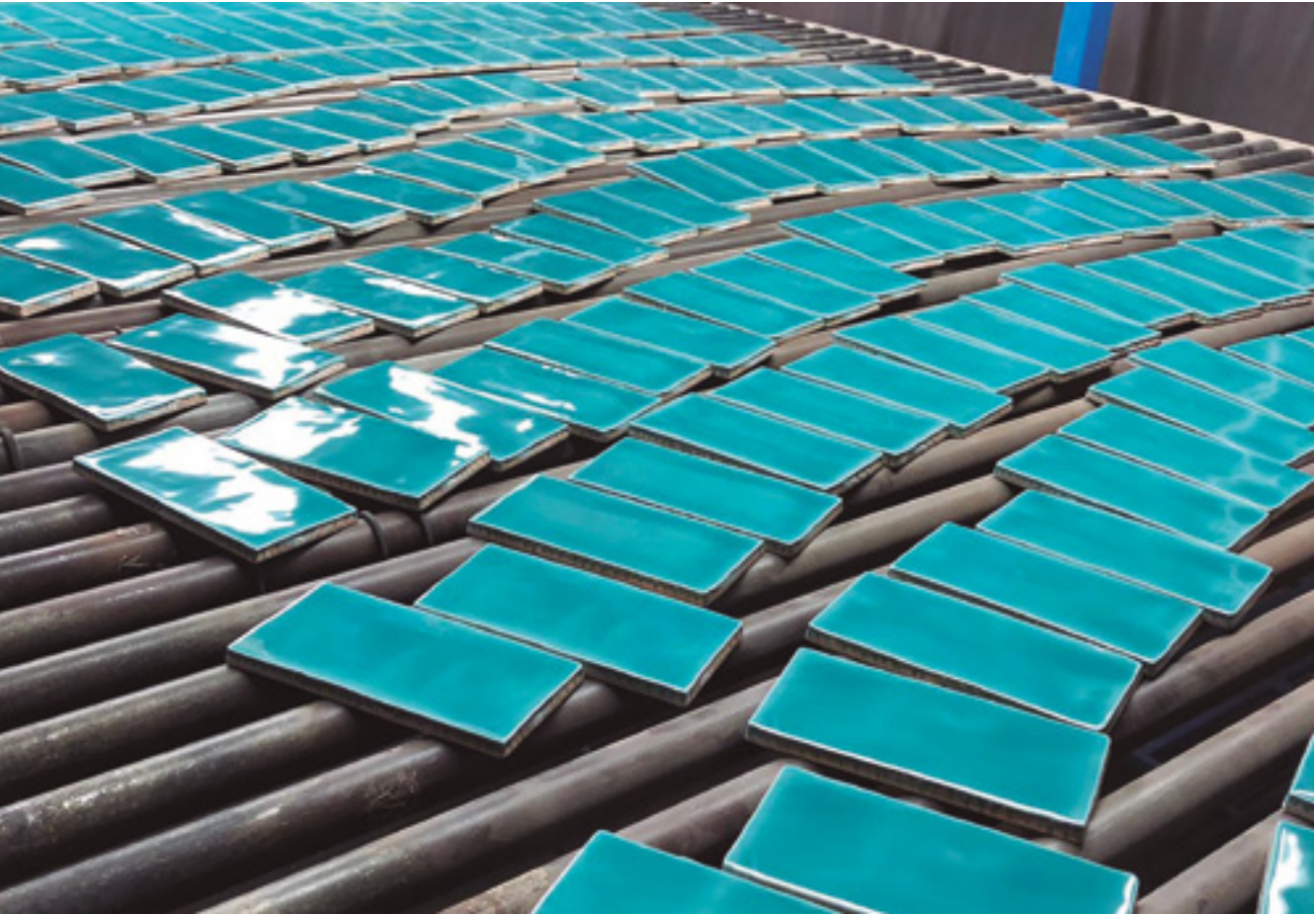

Fine print: Minimum order quantity - 3,000 SQ FT.
Development fee: \$300 fee reimbursed upon product order

INSTALLATION & MAINTENANCE

PRIOR TO INSTALLATION

The surface where the product is going to be installed must be clean and level.

We strongly recommend dry laying prior to installation. Blending of the ceramic tile glaze is key to insuring a pleasing overall look to your room. This will resolve any color or size issues prior to installation and will serve as a review of tile placement.

We recommend all our tiles to be installed using the prevailing guidelines as set forth in the TCNA (Tile Council of North America) Handbook and the ANSI (American National Standards Institute) specifications.

Installation should be carried out by experienced personnel.

CERAMIC TILES

SETTING MATERIALS

For Porcelain Tiles, install with any high-quality adhesive recommended for porcelain tiles. This must also be suitable for the environment they will have to withstand.

Fitting with traditional mortars does not ensure good adhesion.

For Glass tiles, install with any high-quality adhesives recommended for glass floor tiles. This must also be suitable for the environment they will have to withstand. Fitting with traditional mortars does not ensure good adhesion.

For Mud Installations, all setting materials and installation methods should be performed using the prevailing guidelines set by the Tile Council of America and the ANSI Specifications.

GROUT

Unsanded grout is typically used for grout joints 1/8" or smaller.

Sanded grout is recommended for grout joints larger than 1/8", as long as the excess material is removed with a damp sponge. Using notched trowels or grout floats may scratch the tile. Special care should be exercised with high sheen surfaces.

We do not recommend contrasting color grouts on our crackled glazed tiles.

The color of the grout should be as close as possible to the color of your tile.

NOTE: *We use Sanded grout in most of our display boards to keep them intact during shipping.*

METHOD

Follow the appropriate standard ceramic procedures provided by the TCNA (Tile Council of North America) Handbook and the ANSI (American National Standards Institute) specifications.

The surfaces of raised/dimensional decorative accents, borders or liners can be taped off during grouting to facilitate cleanup.

To help keep border, liner and molding grout joints tight, offset the joints between field tile, trim and accent rows.

SEALING

Sealing is not required for Solid Glazes.

Sealing is mandatory for Crackle Glazes. We recommend sealing our crackled glaze tiles with a solvent based penetrating sealer before and after grouting.

1. The sealer penetrates the fine, hairline fissures in the glaze and prevents dirt and dusk darkening the crackle over a period of time.
2. Sealing the crackled glaze makes it easier to maintain and clean.
3. Proper application of the sealer (wipe off any excess from glazed surface) will not harm or change the appearance of the tile.
4. Reapply to grout joints and crackle glazes periodically as needed. When water no longer beads on the surface of the joints, resealing is required.

We recommend the following products and procedures:

Once the tile is mounted on the wall and before grouting, the tile surface must be clean and free of dirt and dust. Use the **FILA MP90 - Natural Look Penetrating Sealer** (Available in our Price List) which is a solvent based

sealer. Apply an even coat of FILAMP90 with a paintbrush or lambswool applicator pad. Wait 24 Hours to allow the product to cure. Apply grout with a sponge evenly distributing grout over joints. **Do not use a grout float.**

NOTE: *When using Contrasting Color Grouts, it is imperative that the tiles are thoroughly sealed to avoid the discoloration from the grout pigment. Please follow the mixing grouting instructions of the Grout Manufacturer.*

Once the grouting is completed and allowed to dry, the surface of the tiles must be cleaned using **FILA CLEANER - Neutral Cleaner** (Available in our Price List) observing the following guidelines: Dilute to 1:30. Clean the surface with a cloth and scrubbing brush. Remove any residue and rinse thoroughly.

After the thorough cleaning of the surface and grout residue, the tile will need to be resealed using the **FILA MP90 - Natural Look Penetrating Sealer** (Available in our Price List) observing the following guidelines: Apply an even coat of FILAMP90 with a paintbrush or lambswool applicator pad. Wipe off product excess after 15 minutes, making sure to rub the product and help its complete penetration into the material. Wait 24 Hours to allow the product to cure.

NOTE: *Future Sealing of the product should be done if you see any discoloration/darkening in the body of the tile. This will vary by end usage, care and maintenance products and tools used.*

If you use any other sealer, please check with the manufacturer for the proper instructions and products to use for sealing crackled glaze ceramic tile.

MAINTENANCE

For walls: clean tile regularly with a non-abrasive/non-acidic, mild and PH neutral cleaner.

We recommend **FILA CLEANER - Neutral Cleaner** (Available in our Price List) for all cleaning purposes of our tile.

Sealer: Reapply to grout joints and crackle glazes periodically as needed. When water no longer beads on the surface of the joints, resealing is required.

PORCELAIN TILES & GLASS MOSAICS

SETTING MATERIALS

For Porcelain tiles, install with any high-quality adhesive recommended for porcelain tiles. This must also be suitable for the environment they will have to withstand. Fitting with traditional mortars does not ensure good adhesion.

For Glass tiles, install with any high-quality adhesives recommended for glass floor tiles. This must also be suitable for the environment they will have to withstand. Fitting with traditional mortars does not ensure good adhesion.

For Mud Installations, all setting materials and installation methods should be performed using the prevailing guidelines set by the Tile Council of America and the ANSI Specifications.

GROUT

For Porcelain tiles, we recommend using a minimum of 5/64-inch (0.08" or 2 mm) spacers for a perfect alignment of the tiles. It will also be necessary to make small adjustments by hand to compensate for the natural dimensional variations of the tiles. The joints should be filled in with appropriate materials according to the specifications given by the joint filling material manufacturer. We do not recommend the installation of porcelain tiles without joints.

METHOD

Follow the appropriate standard ceramic, porcelain and glass tile installation procedures provided by the TCNA (Tile Council of North America) Handbook and the ANSI (American National Standards Institute) specifications.

MAINTENANCE

Clean the tile regularly with a non-abrasive/non-acidic, mild and PH neutral cleaner.

We recommend **FILA CLEANER - Neutral Cleaner** (Available in our Price List) for all cleaning purposes of our tile.

Use products which are suitable to eliminate the remains of mortar, cement, etc. Never use an acidic cleaning agent on newly installed flooring because the acid reacts with the unset cement and can damage the seals, or insoluble compounds can be deposited on the surface of the paving.

Do not use metal scrapers or abrasive pads.

Daily cleaning, after use, will be made particularly easy as it only requires clean water and a very well-wrung cloth. In areas where the tile could be especially messy (kitchens), a detergent with bleach or ammonia can be added to water, although in this case we always recommend giving a final rinse with clear water. Do not use waxes, oils or similar products. In some cases, we can find ourselves in the situation of having to clean very dry and specific stains, which cannot be removed with a damp cloth, but that will disappear if we apply concentrated bleach (the one for floors, not the one used for clothes) and leave it to dry. For especially resistant stains it may be necessary to repeat the process.

PLEASE NOTE

Due to the nature of our tile, a certain amount of variation in color, shading, surface and texture are to be expected.

Use of the tile constitutes acceptance. We assume no responsibility for installation.

The installation information provided is to be used as a guideline only and should be discussed with a professional and accredited tile installer.

For floor surfaces, water, grease, oil, etc. create slippery conditions. Floor applications with exposure to these conditions require extra caution in product selection and maintenance.

TECHNICAL GUIDE

Size specifications, tile thicknesses, applications guidelines, cleaning recommendations... **and much more!**



ICON LEGEND

-  Wall
-  Showers
-  Shower Floor
-  Residential Floor
-  Indoor
-  Pool Waterlines Water Fountains
-  Outdoor Cooking Bar Spaces
-  Fireplace Surrounds

*For further specifications, please refer to technical features



FIELD TILES		
SIZE	SIZE SPECIFICATIONS	THICKNESS*
FLAT TILE		
3"x6"	2.953"x5.906" (75mm x 150mm)	0.256" (6.5mm)
6"x6"	5.906"x5.906" (150mm x 150mm)	0.236" (6mm)
4"x8"	3.937"x7.874" (100mm x 200mm)	0.295" (7.5mm)
2"x8"	1.969"x7.874" (50mm x 200mm)	0.275" (7mm)
3"x12"	2.953"x11.811" (75mm x 300mm)	0.307" (7.8mm)
4"x12"	3.937"x11.811" (100mm x 300mm)	0.295" (7.5mm)
6"x12"	5.906"x11.811" (150mm x 300mm)	0.307" (7.8mm)
6" Arabesque	5.906"x5.906" (150mm x 150mm)	0.299" (7.6mm)
BEVELED TILE		
3"x6" Beveled	2.953"x5.906" (75mm x 150mm)	0.303" (7.7mm)
4"x8" Beveled	3.937"x7.874" (100mm x 200mm)	0.295" (7.5mm)
DECORATIVE ACCESORIES & FINISHING TOUCHES		
Bar Liner 1"x6"	0.984"x5.905" (25mm x 150mm)	0.709" (18mm)
Bar Liner 1.2"x8"	1.299"x7.913" (33mm x 201mm)	0.709" (18mm)
Flat Liner 1"x6"	1.181"x5.866 (30mm x 149mm)	0.197" (5mm)
Stripe Liner 0.7"x 6"	0.709"x5.905" (18mm x 150mm)	0.472" (12mm)
Stripe Liner 1"x12"	0.827"x11.811" (21mm x 300mm)	0.551" (14mm)
Corner Trim 0.8"x12"	0.827"x11.811" (21mm x 300mm)	0.551" (14mm)
Quarter Round 1"x6"	1.024"x5.945" (26mm x 151mm)	0.354" (9mm)
Quarter Round 1"x8"	1.024"x7.913" (26mm x 201mm)	0.354" (9mm)
Chair Molding 1.4"x6"	1.457"x5.905" (37mm x 150mm)	0.787" (20mm)
Chair Molding 2"x8"	2.008"x7.874" (51mm x 200mm)	0.827" (21mm)
Rail Molding 2"x6"	2.008"x5.945" (51mm x 151mm)	0.669" (17mm)
Rail Molding 2"x8"	2.008"x7.913" (51mm x 201mm)	0.669" (17mm)
Crown Molding 3"x6"	2.992"x5.905" (76mm x 150mm)	0.748" (19mm)
Crown Molding 2.8"x12"	2.795"x11.811" (71mm x 300mm)	0.827" (21mm)
Base Board (Glazed Top Edge) 6"x6"	5.905"x5.905" (150mm x 150mm)	0.591" (15mm)
Base Board (Glazed Top Edge) 6"x12"	5.945"x11.811" (151mm x 300mm)	0.669" (17mm)
Cove Base 6"x6"	5.905"x5.905" (150mm x 150mm)	0.787" (20mm)

*Thickness is understood as the highest point of the tile.

APPLICATIONS		
	SUITABLE RESIDENTIAL	SUITABLE COMMERCIAL
Bathroom Walls	YES	YES
Shower Walls	YES	YES
Kitchen Walls	YES	YES
Countertops	YES	NO
Fireplace Surrounds	YES	YES
Outdoor Cooking / Bar Spaces	YES	YES
Pool Waterlines / Water Fountains	NO	NO
Floors	NO	NO
PERFORMANCE CHARACTERISTICS		
	TEST METHOD ATSM / ISO	RESULT
Water Absorption	C-373 / 10545-3	Pass
Breaking Strength	C-648 / 10545-4	Pass
Chemical Resistance	C-651 / 10545-14	Resistant
Facial Dimensions	C-499 / 10545-2	Pass
Range of Thickness	C-499 / 10545-2	Pass
Warpage	C-485 / 10545-2	Pass

INSTALLATION	
GROUT JOINT RECOMMENDATION	SHADE VARIATION
1/8"	V1 - Uniform Appearance

CLEANING RECOMMENDATIONS
Routine with a non-abrasive/non-acidic, mild and PH neutral cleaner

CHARACTERISTICS	
Glaze	Solid
Surface Sheen	Glossy
Texture	Smooth

Due to the nature of our tile, a certain amount of variation in color, shading, surface and texture are to be expected.



FIELD TILES		
SIZE	SIZE SPECIFICATIONS	THICKNESS*
FLAT TILE		
2.8"x5.8"	2.874"x5.827" (73mm x 148mm)	0.346" (8.8mm)
5.8"x5.8"	5.827"x5.827" (148mm x 148mm)	0.346" (8.8mm)
3."8x7.8"	3.858"x7.795" (98mm x 198mm)	0.346" (8.8mm)
1.9"x7.8"	1.890"x7.795" (48mm x 198mm)	0.346" (8.8mm)
BEVELED TILE		
6" Arabesque Beveled	5.906"x5.906" (150mm x 150mm)	0.488" (12.4mm)
6" Tear Drop Beveled	5.2362"x5.906" (133mm x 150mm)	0.460" (11.7mm)
FRAMED TILE		
2.8"x5.8" Framed	2.874"x5.827" (73mm x 148mm)	0.543" (13.8mm)

DECORATIVE ACCESORIES & FINISHING TOUCHES		
Ponciana Liner 1"x7.8"	0.984"x7.795" (25mm x 198mm)	0.394" (10mm)
Round Bar Liner 1.2"x7.8"	1.102"x7.795" (28mm x 198mm)	0.669" (17mm)
Stripe Liner 0.7"x7.8"	0.709"x7.795" (18mm x 198mm)	0.512" (13mm)
Quarter Round 1"x5.8"	0.945"x5.827" (24mm x 148mm)	0.394" (10mm)
Rail Molding 2.8"x7.8"	2.992"x7.795" (76mm x 198mm)	1.102" (28mm)
Chair Molding 2"x7.8"	2.008"x7.795" (51mm x 198mm)	0.866" (22mm)
Base Board (Glazed Top Edge) 5.8"x5.8"	5.827"x5.827" (148mm x 148mm)	0.512" (13mm)

*Thickness is understood as the highest point of the tile.

APPLICATIONS		
	SUITABLE RESIDENTIAL	SUITABLE COMMERCIAL
Bathroom Walls	YES	YES
Shower Walls	YES	YES
Kitchen Walls	YES	YES
Countertops	YES	NO
Fireplace Surrounds	YES	YES
Outdoor Cooking / Bar Spaces	YES	YES
Pool Waterlines / Water Fountains	NO	NO
Floors	NO	NO
PERFORMANCE CHARACTERISTICS		
	TEST METHOD ATSM / ISO	RESULT
Water Absorption	C-373 / 10545-3	Pass
Breaking Strength	C-648 / 10545-4	Pass
Chemical Resistance	C-651 / 10545-14	Resistant
Facial Dimensions	C-499 / 10545-2	Pass
Range of Thickness	C-499 / 10545-2	Pass
Warpage	C-485 / 10545-2	Pass

INSTALLATION	
GROUT JOINT RECOMMENDATION	SHADE VARIATION
1/8"	V1 - Uniform Appearance

CLEANING RECOMMENDATIONS
Routine with a non-abrasive/non-acidic, mild and PH neutral cleaner

CHARACTERISTICS	
Glaze	Solid with subtle movement
Surface Sheen	Glossy
Texture	Slightly Uindulated

Due to the nature of our tile, a certain amount of variation in color, shading, surface and texture are to be expected.



FIELD TILES		
SIZE	SIZE SPECIFICATIONS	THICKNESS*
FLAT TILE		
4"x4"	3.917"x3.917" (99.5mm x 99.5mm)	0.295" (7.5mm)
4"x6"	3.957"x5.913" (100.5mm x 150.2mm)	0.295" (7.5mm)
8"x8"	7.874"x7.874" (200mm x 200mm)	0.295" (7.5mm)
DECORATIVE ACCESORIES & FINISHING TOUCHES		
Stripe Liner 0.7"x8" (One Overglazed Edge)	0.709"x7.913" (18mm x 201mm)	0.512" (13mm)
Quarter Round 1"x8"	1.024"x7.874" (26mm x 200mm)	0.354" (9mm)
Chair Molding 2"x8"	2.008"x7.874" (51mm x 200mm)	0.827" (21mm)
Base Board (Glazed Top Edge) 4"x8"	3.976"x7.874" (101mm x 200mm)	0.591" (15mm)
APPLICATIONS		
	SUITABLE RESIDENTIAL	SUITABLE COMMERCIAL
Bathroom Walls	YES	YES
Shower Walls	YES	YES
Kitchen Walls	YES	YES
Countertops	YES	NO
Fireplace Surrounds	YES	YES
Outdoor Cooking / Bar Spaces	YES	YES
Pool Waterlines / Water Fountains	NO	NO
Floors	NO	NO
PERFORMANCE CHARACTERISTICS		
	TEST METHOD ATSM / ISO	RESULT
Water Absorption	C-373 / 10545-3	Pass
Breaking Strength	C-648 / 10545-4	Pass
Chemical Resistance	C-651 / 10545-14	Resistant
Facial Dimensions	C-499 / 10545-2	Pass
Range of Thickness	C-499 / 10545-2	Pass
Warpage	C-485 / 10545-2	Pass

INSTALLATION	
GROUT JOINT RECOMMENDATION	SHADE VARIATION
1/8"	V3 - Moderate Variation

CLEANING RECOMMENDATIONS
Routine with a non-abrasive/non-acidic, mild and PH neutral cleaner

CHARACTERISTICS	
Glaze	Solid with high color variation
Surface Sheen	Glossy
Texture	Smooth

*Thickness is understood as the highest point of the tile.

Due to the nature of our tile, a certain amount of variation in color, shading, surface and texture are to be expected.

This collection is characterized by its shade variation. Some colors in the series have more variation than others. Expect shade variation between the individual field tiles and between field and trim within each color. Due to the shape of the pieces and the nature of production, this is especially true for variation between field and trims. Trim pieces like quarter rounds, finishing edges and other moldings may have more glaze pooling and different pooling effects than other pieces. Expect variation within each run, and from production to production. IT IS IMPORTANT TO BLEND TILE WITHIN EACH CARTON AND FROM MULTIPLE CARTONS DURING INSTALLATION. This is best achieved by laying out the material prior to installation.



FIELD TILES		
SIZE	SIZE SPECIFICATIONS	THICKNESS*
UNDULATED TILE		
2.5"x5.1"	2.520"x5.118" (64mm x 130mm)	0.295" (7.5mm)
2.5"x10.3"	2.520"x10.315" (64mm x 262mm)	0.303" (7.7mm)
5.1"x5.1"	5.118"x5.118" (130mm x 130mm)	0.303" (7.7mm)
DECORATIVE ACCESORIES & FINISHING TOUCHES		
Liner (One Overglazed Edge) 0.6"x10.3"	0.630"x10.315" (16mm x 262mm)	0.354" (9mm)
Quarter Round 1"x10.3"	1.024"x10.315" (26mm x 262mm)	0.394" (10mm)
Molding 2"x10.3"	2.008"x10.315" (51mm x 262mm)	0.591" (15mm)
Base Board (Glazed Top Edge) 4"x10.3"	3.976"x10.315" (101mm x 262mm)	0.551" (14mm)
APPLICATIONS		
	SUITABLE RESIDENTIAL	SUITABLE COMMERCIAL
Bathroom Walls	YES	YES
Shower Walls	YES	YES
Kitchen Walls	YES	YES
Countertops	YES	NO
Fireplace Surrounds	YES	YES
Outdoor Cooking / Bar Spaces	YES	YES
Pool Waterlines / Water Fountains	NO	NO
Floors	NO	NO
PERFORMANCE CHARACTERISTICS		
	TEST METHOD ATSM / ISO	RESULT
Water Absorption	C-373 / 10545-3	Pass
Breaking Strength	C-648 / 10545-4	Pass
Chemical Resistance	C-651 / 10545-14	Resistant
Facial Dimensions	C-499 / 10545-2	Pass
Range of Thickness	C-499 / 10545-2	Pass
Warpage	C-485 / 10545-2	Pass

*Thickness is understood as the highest point of the tile.

INSTALLATION	
GROUT JOINT RECOMMENDATION	SHADE VARIATION
1/8"	V3 - Moderate Variation

CLEANING RECOMMENDATIONS
Routine with a non-abrasive/non-acidic, mild and PH neutral cleaner

CHARACTERISTICS	
Glaze	Solid with subtle movement and high color variation
Surface Sheen	Glossy and Matte
Texture	Slightly Undulated

Due to the nature of our tile, a certain amount of variation in color, shading, surface and texture are to be expected.

This collection is characterized by its shade variation. Some colors in the series have more variation than others. Expect shade variation between the individual field tiles and between field and trim within each color. Due to the shape of the pieces and the nature of production, this is especially true for variation between field and trims. Trim pieces like quarter rounds, finishing edges and other moldings may have more glaze pooling and different pooling effects than other pieces. Expect variation within each run, and from production to production. IT IS IMPORTANT TO BLEND TILE WITHIN EACH CARTON AND FROM MULTIPLE CARTONS DURING INSTALLATION. This is best achieved by laying out the material prior to installation.



FIELD TILES		
SIZE	SIZE SPECIFICATIONS	THICKNESS*
UNDULATED TILE		
3"x6"	2.953"x5.905" (75mm x 150mm)	0.366" (9.3mm)
3"x12"	2.953"x11.811" (75mm x 300mm)	0.366" (9.3mm)
TEXTURED TILE		
3"x6" Textured	2.953"x5.905" (75mm x 150mm)	0.366" (9.3mm)
3"x12" Textured	2.953"x11.811" (75mm x 300mm)	0.366" (9.3mm)
3"x6" Waves	2.953"x5.905" (75mm x 150mm)	0.366" (9.3mm)
3"x12" Waves	2.953"x11.811" (75mm x 300mm)	0.366" (9.3mm)

DECORATIVE ACCESORIES & FINISHING TOUCHES		
Bar Liner 1"x6"	0.984"x5.905" (25mm x 150mm)	0.669" (17mm)
Bar Liner 1"x12"	0.984"x11.771" (25mm x 299mm)	0.669" (17mm)
Quarter Round 1"x6"	0.905"x5.827" (23mm x 148mm)	0.394" (10mm)
Molding 2.4"x6"	2.401"x5.827" (61mm x 148mm)	1.102" (28mm)
Molding 2.4"x12"	2.401"x11.771" (61mm x 299mm)	1.102" (28mm)
Base Board (Glazed Top Edge) 5.1"x6"	5.157"x5.827" (131mm x 148mm)	0.512" (13mm)
Base Board (Glazed Top Edge) 5.1"x12"	5.118"x11.811" (130mm x 300mm)	0.512" (13mm)

*Thickness is understood as the highest point of the tile.

APPLICATIONS		
	SUITABLE RESIDENTIAL	SUITABLE COMMERCIAL
Bathroom Walls*	YES	YES
Shower Walls*	YES	YES
Kitchen Walls*	YES	YES
Countertops	NO	NO
Fireplace Surrounds*	YES	YES
Outdoor Cooking / Bar Spaces*	YES	YES
Pool Waterlines / Water Fountains	NO	NO
Floors	NO	NO
	TEST METHOD ATSM / ISO	RESULT
Water Absorption	C-373 / 10545-3	Pass
Breaking Strength	C-648 / 10545-4	Pass
Chemical Resistance**	C-651 / 10545-14	Resistant
Facial Dimensions	C-499 / 10545-2	Pass
Range of Thickness	C-499 / 10545-2	Pass
Warpage	C-485 / 10545-2	Pass
INSTALLATION		
GROUT JOINT RECOMMENDATION	SHADE VARIATION	
3/8"	V1 - Uniform Appearance	
CLEANING RECOMMENDATIONS		
Routine with a non-abrasive/non-acidic, mild and PH neutral cleaner		
SEALING GUIDELINES		
Solvent based penetrating sealer suitable for ceramic tiles		
CHARACTERISTICS		
Glaze	Crackle with subtle movement	
Surface Sheen	Semi-Matte	
Texture	Slightly Undulated	

*Crackle tiles must be properly sealed. (See SEALING instructions in INSTALLATION & MAINTENANCE guidelines)

** In order to accomplish this test, the tile must be properly sealed.

Due to the nature of our tile, a certain amount of variation in color, shading, surface and texture are to be expected.



FIELD TILES		
SIZE	SIZE SPECIFICATIONS	THICKNESS*
UNDULATED TILE		
3"x6"	2.913"x5.827" (74mm x 148mm)	0.307" (7.8mm)
3"x9"	2.913"x8.740" (74mm x 222mm)	0.319" (8.1mm)
DECORATIVE ACCESORIES & FINISHING TOUCHES		
Stripe Liner 0.8"x6"	0.787"x5.827" (20mm x 148mm)	0.472" (12mm)
Bar Liner 1"x6"	0.984"x5.866" (25mm x 149mm)	0.630" (16mm)
Quarter Round 1"x6"	0.984"x5.827" (25mm x 148mm)	0.354" (9mm)
Chair Molding 1.2"x6"	1.181"x5.866" (30mm x 149mm)	0.787" (20mm)
Rail Molding 2"x6"	1.968"x5.827" (50mm x 148mm)	0.945" (24mm)
Base Board (Glazed Top Edge) 6"x6"	5.866"x5.866" (149mm x 149mm)	0.551" (14mm)
APPLICATIONS		
	SUITABLE RESIDENTIAL	SUITABLE COMMERCIAL
Bathroom Walls**	YES	YES
Shower Walls**	YES	YES
Kitchen Walls**	YES	YES
Countertops	NO	NO
Fireplace Surrounds**	YES	YES
Outdoor Cooking / Bar Spaces**	YES	YES
Pool Waterlines / Water Fountains	NO	NO
Floors	NO	NO
PERFORMANCE CHARACTERISTICS		
	TEST METHOD ATSM / ISO	RESULT
Water Absorption	C-373 / 10545-3	Pass
Breaking Strength	C-648 / 10545-4	Pass
Chemical Resistance***	C-651 / 10545-14	Resistant
Facial Dimensions	C-499 / 10545-2	Pass
Range of Thickness	C-499 / 10545-2	Pass
Warpage	C-485 / 10545-2	Pass

INSTALLATION	
GROUT JOINT RECOMMENDATION	SHADE VARIATION
1/8"	V1 - Uniform Appearance

CLEANING RECOMMENDATIONS
Routine with a non-abrasive/non-acidic, mild and PH neutral cleaner
SEALING GUIDELINES
Solvent based penetrating sealer suitable for ceramic tiles

CHARACTERISTICS	
Glaze	Crackle with subtle movement
Surface Sheen	Glossy
Texture	Slightly Undulated

*Thickness is understood as the highest point of the tile.

**Crackle tiles must be properly sealed. (See SEALING instructions in INSTALLATION & MAINTENANCE guidelines).

*** In order to accomplish this test, the tile must be properly sealed.

Due to the nature of our tile, a certain amount of variation in color, shading, surface and texture are to be expected.



FIELD TILES		
SIZE	SIZE SPECIFICATIONS	THICKNESS*
FLAT TILE		
3"x6"	2.953"x5.906" (75mm x 150mm)	0.256" (6.5mm)
2"x8"	1.969"x7.874" (50mm x 200mm)	0.275" (7mm)
4"x8"	3.937"x7.874" (100mm x 200mm)	0.295" (7.5mm)
BEVELED TILE		
3"x6" Beveled	2.953"x5.906" (75mm x 150mm)	0.303" (7.7mm)
DECORATIVE ACCESORIES & FINISHING TOUCHES		
Bar Liner 1"x6"	0.984"x5.905" (25mm x 150mm)	0.709" (18mm)
Stripe Liner 0.7"x6"	0.709"x5.905" (18mm x 150mm)	0.472" (12mm)
Quarter Round 1"x6"	1.024"x5.905" (26mm x 150mm)	0.354" (9mm)
Chair Molding 1.4"x6"	1.457"x5.905" (37mm x 150mm)	0.787" (20mm)
Chair Molding 2"x8"	1.968"x7.874" (50mm x 200mm)	0.827" (21mm)
Rail Molding 2"x6"	2.007"x5.945" (51mm x 151mm)	0.669" (17mm)
Crown Molding 3"x6"	2.992"x5.905" (76mm x 150mm)	0.748" (19mm)
Base Board (Glazed Top Edge) 6"x6"	5.905"x5.905" (150mm x 150mm)	0.591" (15mm)
APPLICATIONS		
	SUITABLE RESIDENTIAL	SUITABLE COMMERCIAL
Bathroom Walls**	YES	YES
Shower Walls**	YES	YES
Kitchen Walls**	YES	YES
Countertops	NO	NO
Fireplace Surrounds**	YES	YES
Outdoor Cooking / Bar Spaces**	YES	YES
Pool Waterlines / Water Fountains	NO	NO
Floors	NO	NO
PERFORMANCE CHARACTERISTICS		
	TEST METHOD ATSM / ISO	RESULT
Water Absorption	C-373 / 10545-3	Pass
Breaking Strength	C-648 / 10545-4	Pass
Chemical Resistance***	C-651 / 10545-14	Resistant
Facial Dimensions	C-499 / 10545-2	Pass
Range of Thickness	C-499 / 10545-2	Pass
Warpage	C-485 / 10545-2	Pass

INSTALLATION	
GROUT JOINT RECOMMENDATION	SHADE VARIATION
1/8"	V1 - Uniform Appearance

CLEANING RECOMMENDATIONS
Routine with a non-abrasive/non-acidic, mild and PH neutral cleaner
SEALING GUIDELINES
Solvent based penetrating sealer suitable for ceramic tiles

CHARACTERISTICS	
Glaze	Crackle
Surface Sheen	Glossy
Texture	Smooth

*Thickness is understood as the highest point of the tile.

**Crackle tiles must be properly sealed. (See SEALING instructions in INSTALLATION & MAINTENANCE guidelines).

*** In order to accomplish this test, the tile must be properly sealed.

Due to the nature of our tile, a certain amount of variation in color, shading, surface and texture are to be expected.

DIAMONDS



FIELD TILES		
SIZE	SIZE SPECIFICATIONS	THICKNESS*
FLAT TILE		
8"x4"	7.834"x3.937" (199mm x 100mm)	0.354" (9mm)
PILLOW TILE		
8"x4" Pillow	7.834"x3.937" (199mm x 100mm)	0.567" (14.4mm)
FLAT DOT		
3/4"x3/4"	0.827"x0.827" (21mm x 21mm)	0.354" (9mm)
SPHERE DOT		
3/4"x3/4"	0.787"x0.787" (20mm x 20mm)	0.622" (15.8mm)
APPLICATIONS		
	SUITABLE RESIDENTIAL	SUITABLE COMMERCIAL
Bathroom Walls	YES	YES
Shower Walls	YES	YES
Kitchen Walls	YES	YES
Countertops	NO	NO
Fireplace Surrounds**	YES	YES
Outdoor Cooking / Bar Spaces	YES	YES
Pool Waterlines / Water Fountains	NO	NO
Floors	NO	NO
PERFORMANCE CHARACTERISTICS		
	TEST METHOD ATSM / ISO	RESULT
Water Absorption	C-373 / 10545-3	Pass
Breaking Strength	C-648 / 10545-4	Pass
Chemical Resistance	C-651 / 10545-14	Resistant
Facial Dimensions	C-499 / 10545-2	Pass
Range of Thickness	C-499 / 10545-2	Pass
Warpage	C-485 / 10545-2	Pass

INSTALLATION	
GROUT JOINT RECOMMENDATION	SHADE VARIATION
1/8"	V1 - Uniform Appearance

CLEANING RECOMMENDATIONS
Routine with a non-abrasive/non-acidic, mild and PH neutral cleaner

CHARACTERISTICS	
Glaze	Solid
Surface Sheen	Glossy
Texture	Smooth

*Thickness is understood as the highest point of the tile.

**This usage excludes the Silver Diamonds.

Due to the nature of our tile, a certain amount of variation in color, shading, surface and texture are to be expected.



FIELD TILES		
SIZE	SIZE SPECIFICATIONS	THICKNESS*
MESH MOUNTED		
Penny Rounds 3/4" 12.38" x 11.50"	12.362"x11.496" (314mm x 292mm)	0.157" (4mm)
Hexagons 1" 11.97" x 11.69"	11.967"x11.693" (303.97mm x 297mm)	0.236" (6mm)
APPLICATIONS		
	SUITABLE RESIDENTIAL	SUITABLE COMMERCIAL
Bathroom Walls	YES	YES
Shower Walls	YES	YES
Kitchen Walls	YES	YES
Countertops	NO	NO
Fireplace Surrounds	YES	YES
Outdoor Cooking / Bar Spaces	YES	YES
Pool Waterlines / Water Fountains**	YES	YES
Floors***	YES	NO
PERFORMANCE CHARACTERISTICS		
	TEST METHOD ATSM / ISO	RESULT
Water Absorption	C-373 / 10545-3	0.00%
Breaking Strength	C-648 / 10545-4	N/A
Chemical Resistance	C-651 / 10545-14	Resistant
Facial Dimensions	C-499 / 10545-2	Avg. 18.741mm
Range of Thickness	C-499 / 10545-2	Avg. 4.924mm
Warpage	C-485 / 10545-2	0

INSTALLATION	
GROUT JOINT RECOMMENDATION	SHADE VARIATION
5/64"	V2 - Slight Variation

CLEANING RECOMMENDATIONS
Routine with a non-abrasive/non-acidic, mild and PH neutral cleaner

CHARACTERISTICS	
Glaze	Solid with subtle movement
Surface Sheen	Glossy & Matte
Texture	Slightly Undulated

*Thickness is understood as the highest point of the tile.

**Not recommended for freeze-thaw environments.

*** Only Matte Colors (White and Black) and for residential use.

Due to the nature of our tile, a certain amount of variation in color, shading, surface and texture are to be expected.

FLOOR



FIELD TILES	
SIZE	THICKNESS*
GLAZED PORCELAIN TILES	
Square 7.4"x7.4"	0.236" (6mm)
Picket 1.5"x9"	0.236" (6mm)
Hex 8"x9"	0.275" (7mm)
Hex Deco 8"x9"	0.275" (7mm)
RECYCLED GLASS	
Vintage Hex 1" 11.85"x11.41"	0.173" (4.4mm)
Vintage Hex 1" Flower 11.85"x9.13"	0.173" (4.4mm)

APPLICATIONS				
	SUITABLE RESIDENTIAL		SUITABLE COMMERCIAL	
	GLAZED PORCELAIN TILES	RECYCLED GLASS	GLAZED PORCELAIN TILES	RECYCLED GLASS
Bathroom Walls	YES	YES	YES	YES
Shower Walls	YES	YES	YES	YES
Kitchen Walls	YES	YES	YES	YES
Countertops	YES	YES	NO	NO
Fireplace Surrounds	YES	YES	YES	YES
Outdoor Cooking / Bar Spaces	YES	YES	YES	YES
Pool Waterlines / Water Fountains	NO	YES	NO	YES
Floors	YES	YES	NO	NO

PERFORMANCE CHARACTERISTICS			
	TEST METHOD ATSM / ISO	RESULT	
		GLAZED PORCELAIN TILES	RECYCLED GLASS
Target DCOF * >.42Wet	ANSI A137-2012	>0.50	>0.42
PEI Rating	ANSI A137.1-2008 UNE EN ISO 10545-7	White	4
		Bone	3
		Light Gray	3
		Dark Gray	3
		Azure	3
		Black	2
		Wood	3
		Deco	3
Moisture Absorption	ASTM C-373 UNE EN ISO 10545-3	≤ 0.50%*	< 0.50%
Break Strength	ASTM C-648 UNE EN ISO 10545-4	Pass	Pass
Chemical Resistance to Staining	ASTM C-650 UNE EN ISO 10545-14	Resistant	Resistant
Freeze-Thaw Resistance	ASTM C-1026 UNE EN ISO 10545-12	Yes	Yes

INSTALLATION		
GROUT JOINT RECOMMENDATION	SHADE VARIATION	
	GLAZED PORCELAIN TILES	RECYCLED GLASS
Minimum of 5/64"	V1 - Uniform Appearance	V2 - Slight Variation
CLEANING RECOMMENDATIONS		
Routine with a non-abrasive/non-acidic, mild and PH neutral cleaner		
CHARACTERISTICS		
	GLAZED PORCELAIN TILES	RECYCLED GLASS
Glaze	Solid	Solid
Surface Sheen	Semi-Matte	Semi-Matte
Texture	Smooth	Slightly Undulated

*Thickness is understood as the highest point of the tile.
Due to the nature of our tile, a certain amount of variation in color, shading, surface and texture are to be expected.



CONTACT US

Corporate Headquarters

South East Distribution Center

9450 N.W.12th St.
Miami, FL 33172
Office: 305-513-4633
Fax: 305-513-4634
customerservice@adexusa.com

West Coast Distribution Center

2344 E. Walnut Ave.
Fullerton, CA 92831
Office: 714-773-0197
Fax: 714-773-9352
customerservicewest@adexusa.com

North East Distribution Center

1000 Wall St. W.
Lyndhurst, NJ 07071
Office: 201-355-8772
Fax: 201-636-2802
customerservicene@adexusa.com



Our company has an environmental management system in place according to the Norm ISO 14001 certified by European Quality Assurance (EQA)