



# Island Stone<sup>®</sup>



# WELCOME TO ISLAND STONE

CREATING A WORLD OF DIFFERENCE.

2018 marks twenty years since our company began sourcing, processing, and designing stone products that have enhanced homes, commercial projects, luxury retailers and hotels across the world.

Our steadfast team continues to create products that convey both the timelessness of tradition and the modern, chic, and functional aesthetic suited to today's consumer.

This dedication to innovation has allowed our range of tiles and claddings to encompass exceptional glass and wood offerings. We honor the natural world that gives us inspiration and beautiful materials by reusing, recycling, and taking care of these finite resources.

With offices and factories around the globe, every facet of our organization has to operate flawlessly. By constantly evolving our design systems, manufacturing processes, and supply chain management, we work tirelessly to achieve that goal and to better service you, our valued partners.

Our 2018 catalogue showcases Island Stone's latest designs, including updates and improvements on products that have proven successful over the years. All of us at Island Stone thank you for your continued support and look forward to many more years of partnership committed to excellence.



# CONTENTS

---

## 1 NATURAL MOSAICS

---

### Pebble

- 11 Perfect Pebble & Borders
- 12 King Pebble
- 13 Level Pebble
- 14 Petite Pebble
- 14 Celestial Pebble
- 15 Stacked Pebble
- 15 Strip Pebble

### Random

- 19 Random Tile & Borders
- 21 Large Random Tile
- 22 Cobbles
- 23 Random Squares
- 23 Random Lines
- 23 Honeycomb Cobbles
- 23 Honeycomb Random

# 2 GLASS

## Glass

- 31** Beach Tile Square /Rectangle & Trims
- 32** Strand
- 33** Spindrift
- 34** Waveline
- 35** Waveline Mini
- 36** Palms
- 37** Crossroads
- 37** Banyans
- 38** Artifact
- 38** Plaza
- 39** Linear
- 40** Boulevard
- 41** Streamline
- 41** Classic

# 3 QUARRIED STONE

## Cladding

- 52** Strip
- 53** Mini Split
- 53** Briq
- 54** Parallels
- 55** Parallels V
- 56** Uniform
- 56** Cross Strips
- 57** Rustic
- 57** Rustic ii
- 58** V Squares
- 58** Slat Tile
- 59** Vtile
- 59** Vtile II
- 60** Large Vtile

## Profile

- 64** Crescent Interlock
- 64** Crescent Mini Interlock
- 65** Crescent Vtile
- 65** Rhythm Interlock
- 66** Dunes
- 66** New Wave
- 67** Paragon Chevron
- 67** Paragon Hex

## Mosaic

- 70** Classic Mosaic Squares
- 71** Avant Mosaic

## Solid stone

- 75** Solid Square / Rectangle / Large Rectangle & trims

# 4 ISLAND TIMBER

## Reclaimed Indonesian Teak

- 90** Papan Planks
- 91** Rimba
- 91** Kayu V-Wood

# 5 INSTALLATION INFORMATION

## Information

- 94** Pebble & Random
- 96** Glass
- 97** Quarried Stone
- 99** VTile
- 100** Timber



Island Stone®

# 1 NATURAL MOSAICS

# PEBBLE

---

THE HUMBLE BEAUTY OF A VOLCANIC PEBBLE WASHED AND WORN SMOOTH BY CRYSTAL CLEAR MOUNTAIN STREAMS INSPIRED OUR ICONIC PEBBLE TILE. WHY NOT BORROW FROM THE RIVER'S CLEAN DESIGN TO CREATE A SENSE OF SERENITY IN OUR STRUCTURES THAT MIRRORS THE NATURAL WORLD?

---

With the mantra "Many picked. Few chosen!" in mind, we source stones from a myriad of exotic locations and sort them by color and shape. Then, the pebbles are meticulously hand placed into interlocking patterns that imbue them with nature's effortless tranquility.

Evenly surfaced and easily installed, our elegant Pebble Series has proved itself as the mainstay of our business for many years. It isn't hard to see why: the pebble embodies durability and timelessness, without ever sacrificing the beauty of simplicity.







# PERFECT PEBBLE

I3

11 3/4" x 11 3/4"

Pebble size: 1 1/2" - 3" \*pd, pv (larger)

Pebble depth: 1/2"

Interlocking tile.

Tile surface: Natural

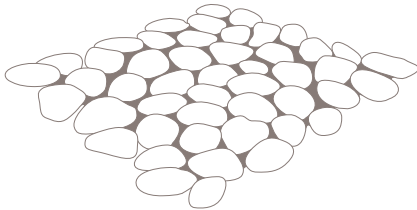

# PEBBLE BORDERS

6" BORDER TILE - B3

6" x 11 3/4"

4" BORDER TILE - B4

4" x 11 3/4"

Pebble size: 3/4" - 1 1/4"

Pebble depth: 1/2"

Interlocking borders

Tile surface: Natural

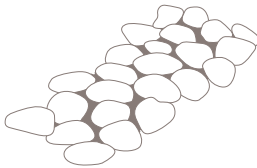
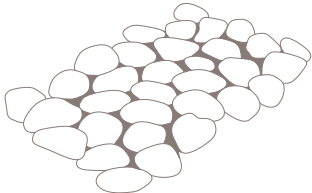

Antique Timor White  
PM

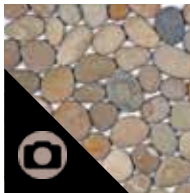

French Tan  
PF



Tundra Sage  
PD



Birds Egg Blend  
PV



Poppy Seed Blend  
PY



Native Earth Blend  
PN



Sumba Speckled  
PS



Medan Charcoal  
PC



Alpine  
PZ



Java Grey  
PR



Nightcaps  
PO



Black & Tan Mix  
PA



# KING PEBBLE

I4

15 3/4" x 15 3/4"

Pebble size: 3" - 5"

Pebble depth: 1/2"

Interlocking tile.

Tile surface: Natural

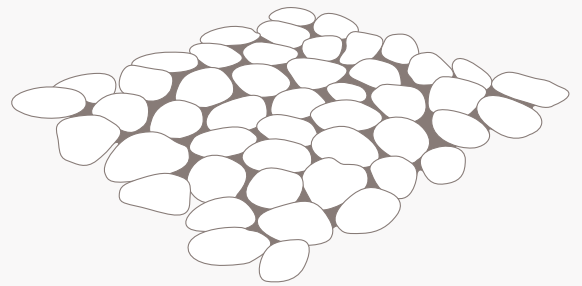

Antique Timor White  
**PM**



French Tan  
**PF**



Flores Green  
**PG**



Java Grey  
**PR**



Medan Charcoal  
**PC**



# LEVEL PEBBLE

**FP1**

11 3/4" x 11 3/4"

Pebble size: 1/2" - 2 1/2"

Pebble depth: 1/2"

Interlocking tile.

Tile surface: Honed

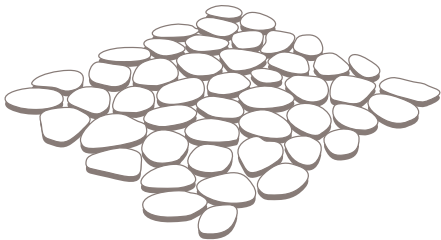

Antique Timor White  
**PM**



French Tan  
**PF**



Java Grey  
**PR**



Medan Charcoal  
**PC**



Malu Grey  
**PH**



Birds Egg Blend  
**PV**



Poppy Seed Blend  
**PY**



Black & Tan Mix  
**PA**



# PETITE PEBBLE

**IB3**

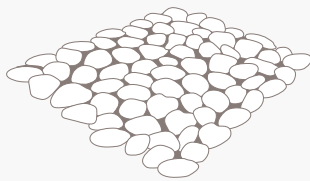

11 3/4" x 11 3/4"  
Pebble size: 3/4" - 1 1/4"  
Stone depth: 1/2"

Interlocking tile.  
Tile surface: Natural



Antique Timor White  
**PM**

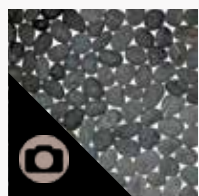

Medan Charcoal  
**PC**

# CELESTIAL PEBBLE

**IB4**

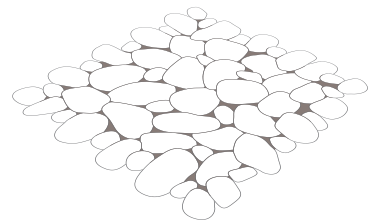

15 3/4" x 15 3/4"  
Pebble size: 2" - 3" & 3/4"  
- 1 1/4"  
Pebble depth: 1/2"

Interlocking tile.  
Tile surface: Natural



Antique Timor White  
& Medan Charcoal  
**CW**

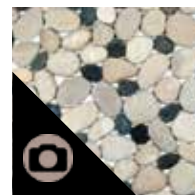

French Tan & Medan  
Charcoal  
**CT**



Flores Green & Antique  
Timor White  
**CG**



Medan Charcoal  
& French Tan  
**CB**



# STACKED PEBBLE

**V1**

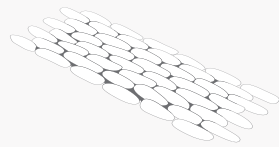

11 3/4" x 6"  
Pebble size: 2" - 3/4"  
Pebble depth: 1"

Interlocking tile.  
Tile surface: Natural



Antique Timor White  
**PW**



French Tan  
**PF**



Medan Charcoal  
**PC**

# STRIP PEBBLE

**SP1**

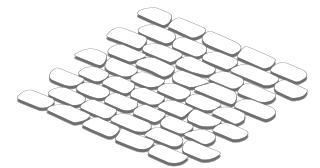

11 3/4" x 11 3/4"  
Pebble size: 2" - 3" X 1 1/4"  
Pebble depth: 1/2"

Interlocking tile.  
Tile surface: Natural



Alpine  
**PZ**

# RANDOM

---

MANY YEARS AGO, WHILE DESIGNING A NEW RANGE OF TILES, A STAFF MEMBER EXCLAIMED “ACAK,” THE INDONESIAN WORD FOR “RANDOM.” THUS, THE NAME WAS COINED AND SINCE THAT DAY, OUR RANDOM SERIES HAS GROWN TO BE ONE OF OUR MOST POPULAR BRANDS.

---

Building the tile is a much like putting together an intricate jigsaw puzzle: the big picture only reveals itself once the last, perfectly selected piece has been inserted.

Once the craftsman places that ultimate piece and is satisfied with the final design, our quality assurance process goes to work.

We ensure almost 100% consistency in terms of color, size and thickness with each tile. It is truly random in name only!

Discover why our Random Tile Series continues to bring life to the finest hotels and residences in the world.







# RANDOM TILE

**I3**

11 3/4" x 11 3/4"  
Stone size: 1" - 3"  
Stone depth: 1/2"  
Interlocking tile.  
Tile surface: Cut & Tumbled

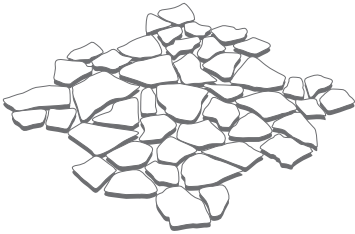

# RANDOM BORDERS

**6" BORDER TILE - B3**  
6" x 11 3/4"

Stone size: 1/2" - 1 1/2"  
Stone depth: 1/2"

**4" BORDER TILE - B4**  
4" x 11 3/4"

Interlocking borders  
Tile surface: Cut & Tumbled

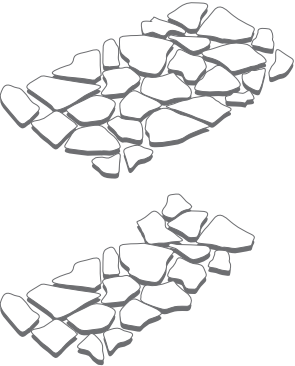

White Marble  
**RW**



White Onyx  
**RZ**



Beige Marble  
**MB**



Latte Quartz  
**QB**



Grey Marble  
**MA**



Honey Quartz  
**QH**



Mixed Quartz  
**QX**



Tan Marble  
**MX**



Swirl Grey  
**MM**



Sterling Grey  
**ML**



Black Basalt  
**MZ**



Beige Marble &  
Quartz Mix  
**MQ**



Beige & Tan  
Marble mix  
**MW**



French Mix  
**XF**



Swirl Grey &  
Beige Mix  
**XK**



Sterling Grey &  
Grey Mix  
**XO**



Sterling Megamix  
**XL**



Tan & Grey  
Marble Mix  
**MG**



Honey Forest Mix  
**XH**



Marble & Quartz  
Megamix  
**XX**



Forest Marble Mix  
**FX**



# LARGE RANDOM TILE

I5

17 3/4" x 17 3/4"  
Stone size: 2" - 5"  
Stone depth: 1/2"

Interlocking tile.  
Tile surface: Cut & Tumbled

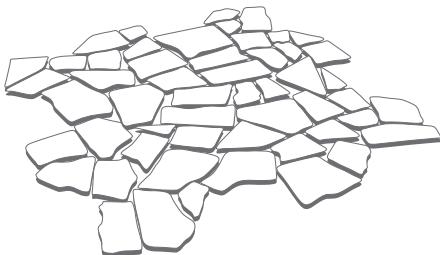

White Marble  
**RW**



Beige Marble  
**MB**



Tan Marble  
**MX**



Grey Marble  
**MA**

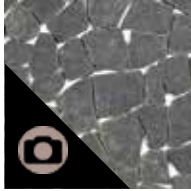

Black Basalt  
**MZ**



**BLEND**

Sterling Megamix  
**XL**



**BLEND**

Beige & Tan  
Marble mix  
**MW**



**BLEND**

Forest Marble Mix  
**FX**



# COBBLES

**RP3**

11 3/4" x 11" 3/4"  
Stone size: 1" - 2"  
Stone depth: 1/2"

Interlocking tile.  
Tile surface: Honed Stone

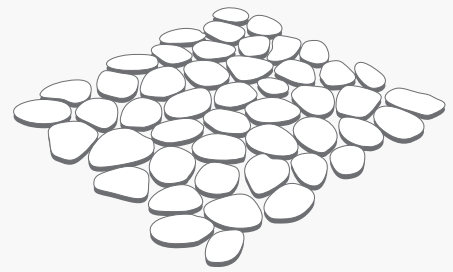

Beige Marble  
**MB**



Latte Quartz  
**QB**



Swirl Grey  
**MM**



Sterling Grey  
**ML**



Grey Marble  
**MA**



Tan Marble  
**MX**



Swirl Grey & Beige Mix  
**XK**



Sterling Grey & Grey Mix  
**XO**



Quartz & Sterling Grey Mix  
**XI**



Multi Grey & Quartz Mix  
**XJ**



Beige & Tan Marble  
**MW**



Sterling Megamix  
**XL**



# RANDOM SQUARES

**RS3**

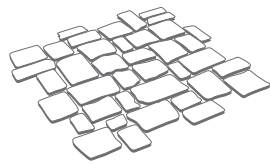

11 3/4" x 11 3/4"  
Stone size: 1" - 2"  
Stone depth: 1/2"

Interlocking tile.  
Tile surface: Cut & Tumbled

# RANDOM LINES

**SR1**

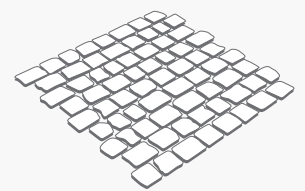

11 3/4" x 11"  
Stone size: 1" - 1 1/2"  
Stone depth: 1/2"

Interlocking tile.  
Tile surface: Honed Stone



Beige Marble  
**MB**



Grey Marble  
**MA**



Tan Marble  
**MX**

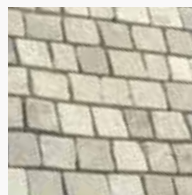

Beige Marble  
**MB**

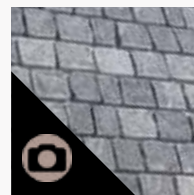

Grey Marble  
**MA**

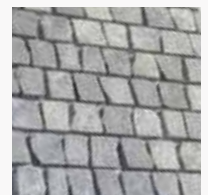

Stirling Grey  
**ML**



Beige & Tan Marble  
**MW**



Marble & Quartz  
Megamix  
**XX**



French Mix Marble  
**XF**



Tan Marble  
**MX**

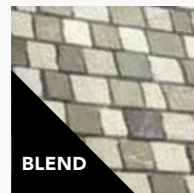

Beige & Tan Marble  
**MW**

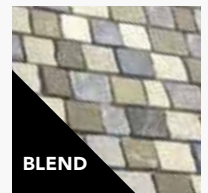

Sterling Megamix  
**XL**



# HONEYCOMB COBBLES

**HC3**

Length (tip to tip) 11 3/4"  
Stone size: 1" - 3"  
Stone depth: 1/2"

Hexagon tile with halo  
edging.  
Tile surface: Halo Edging

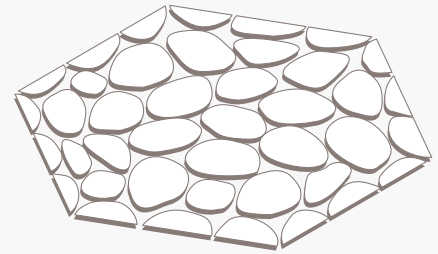

Beige Marble  
**MB**



Sterling Grey  
**ML**



Grey Marble  
**MA**



Tan Marble  
**MX**



Sterling Megamix  
**XL**



Beige & Tan Marble  
**MW**



Grey Mix  
**MLMA**



Beige & Tan Marble  
**MXMB**



Quartz & Tan Mix  
**QBMX**





# HONEYCOMB RANDOM

**HR3**

Length (tip to tip) 11 3/4"  
Stone size: 1" - 3"  
Stone depth: 1/2"

Hexagon tile with halo edging.  
Tile surface: Halo Edging

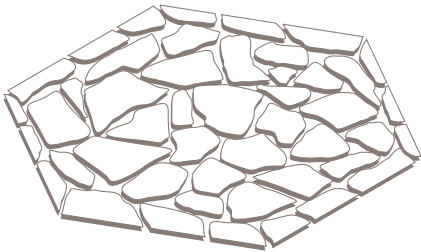

Beige Marble  
**MB**



Sterling Grey  
**ML**



Grey Marble  
**MA**



Tan Marble  
**MX**



Beige & Tan Marble  
**MW**



Sterling Megamix  
**XL**



Island Stone®

# 2 GLASS

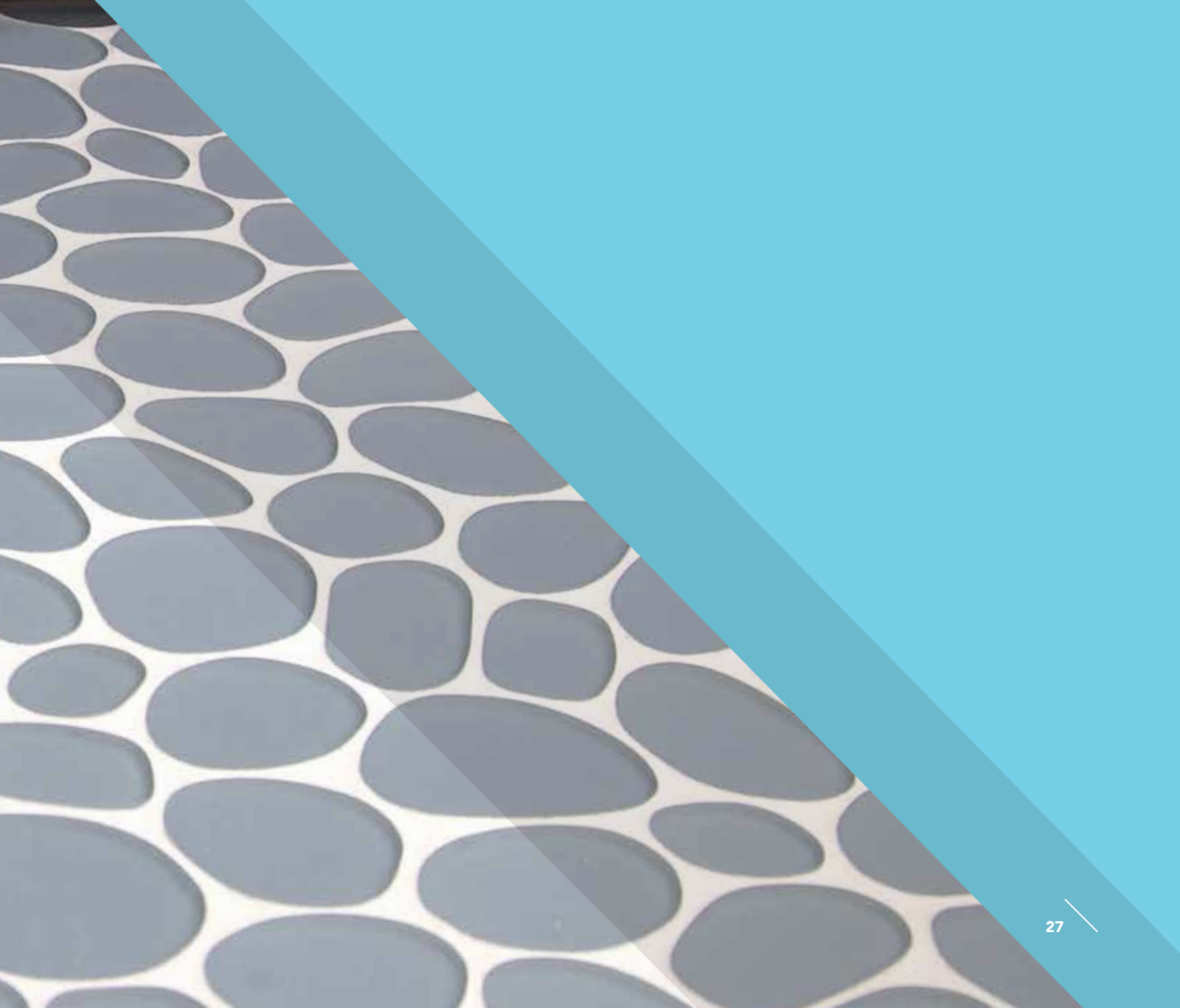

# GLASS

---

WE DRAW INSPIRATION FOR OUR GLASS SERIES FROM PATTERNS FOUND IN NATURE, LIKE THE DELICATE SYMMETRY OF PALM FRONDS OR THE SLEEK LINEAR SHAPE OF THE BANYAN TREE.

---

Island Stone has embraced glass as a medium with inexhaustible potential. We are continually experimenting and innovating this series, and are thrilled to provide an extensive list of options that will bring a grace and lightness to your space.

Glass tile has an elegant air of subtlety, yet it can transform a wall or a room into a memorable piece of art.





# BEACH TILES

## SQUARE - S1

4" x 4"  
9 pieces/sqft  
Tile depth: 1/4"  
Tile surface: Beach Texture  
Individual tile.

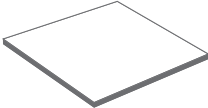

## RECTANGLE - R2

4" x 8"  
4.5 pieces/sqft  
Tile depth: 1/4"  
Tile surface: Beach Texture  
Individual tile.

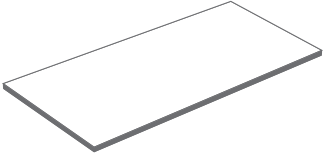

## PENCIL BAR

TR1  
7/8" x 8"  
Tile surface: Matte

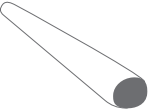

## EXTERNAL RIGHT ANGLE

TR4  
0.1" x 0.1" x 8.0" x 0.3"  
Tile surface: Textured

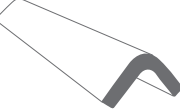



# STRAND RECTANGLE

**R3**

3 5/8" x 12 1/8"  
3.3 pieces/sqft  
Tile depth: 1/4"

Tile surface: Beach Texture  
& Gloss  
Individual tile.

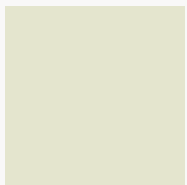
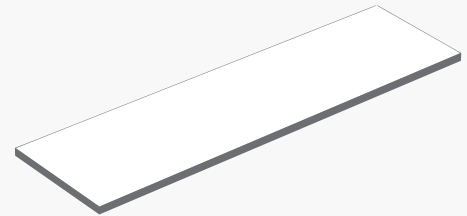

Champagne

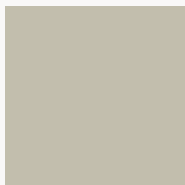

Frangipani



Reed



Breeze



Stratos

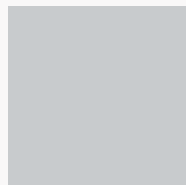

Tule

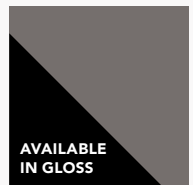

Smoke

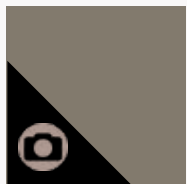

Cement

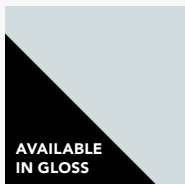

Pure Silk



Oceania



Azure



Margarita



Ginger





# SPINDRIFT

**BG14**

12" x 12"  
Tile depth: 3/16"

Tile surface: Matte  
Pre-formatted mosaic tile

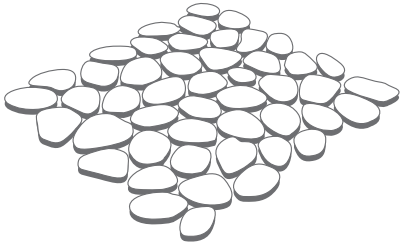

Stratos

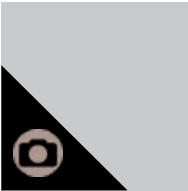

Tule

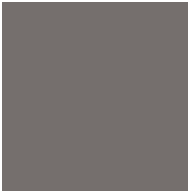

Smoke

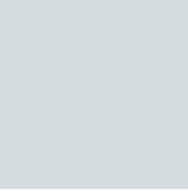

Pure Silk



Azure

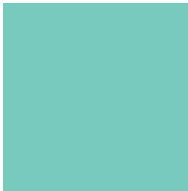

Spring



# WAVELINE

**BG4**

12 1/2" x 12 3/4"  
0.9 pieces/sqft  
Tile depth: 3/16"

Tile surface: Matte  
Interlocking tile.

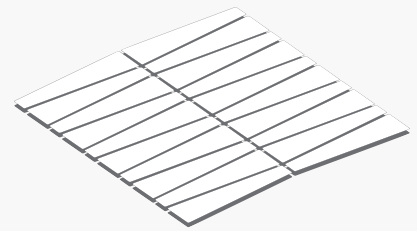

Guava



Frangipani



Seagrass



Reed

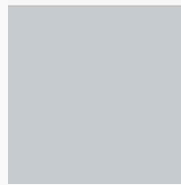

Tule



Smoke



Cement

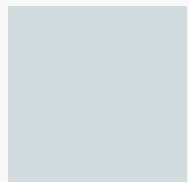

Pure Silk



Oceania



Azure



Spring



Margarita



Breeze



# WAVELINE MINI

**BG9**

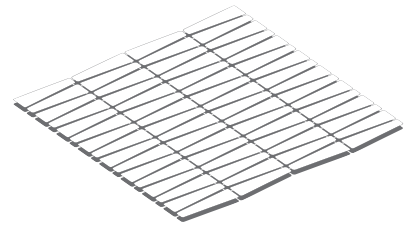

12 1/4" x 12 3/4"  
Tile depth: 3/16"

Tile surface: Matte & Gloss  
Interlocking tile



Sand

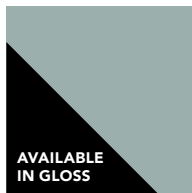

Breeze



Stratos

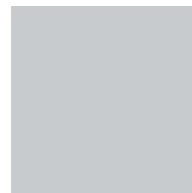

Tule



Smoke



Pure Silk

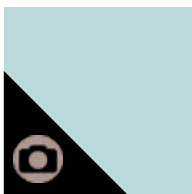

Oceania



Azure



Spring



Margarita



Fresh



# PALMS

**BG11**

9 1/4" x 11 3/4"  
1.25 pieces/sqft  
Tile depth: 3/16"

Tile surface: Matte  
Interlocking tile.

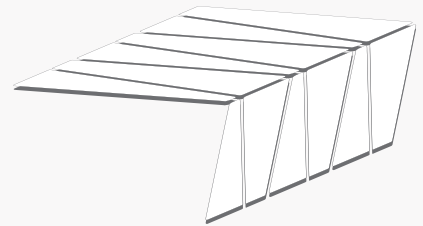

Sand



Breeze



Stratos

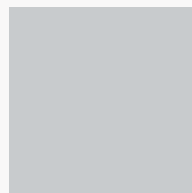

Tule

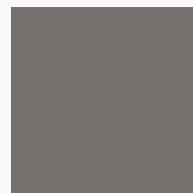

Smoke

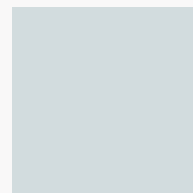

Pure Silk

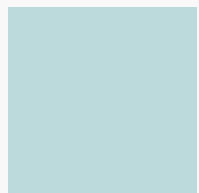

Oceania

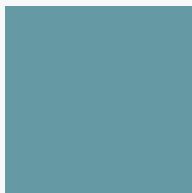

Azure

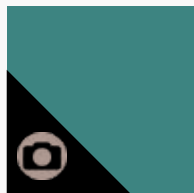

Lagoon



Spring



Margarita



# CROSSROADS

**BG13**

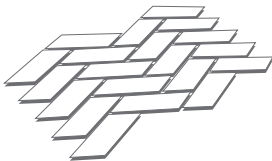

9 1/4" x 16"  
1.0 piece/sqft  
Tile depth: 3/16"

Tile surface: Matte  
Interlocking tile.



Sand

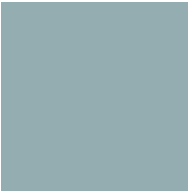

Stratos



Smoke

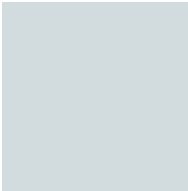

Pure Silk

# BANYANS

**BG12**

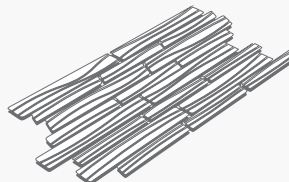

8 1/2" x 16 1/4"  
1.0 piece/sqft  
Tile depth: 3/16"

Tile surface: Gloss with line texture.  
Interlocking tile.



Frangipani

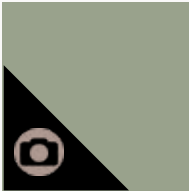

Reed



Smoke

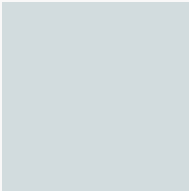

Pure Silk



## ARTIFACT

**BG6**

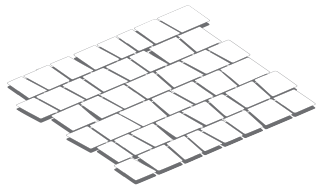

11" x 11 1/2" x 1/4"  
1.0 piece/sqft

Interlocking tile.  
Tile surface: Matte



Seagrass

Stratos

Smoke

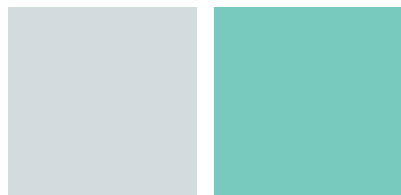

Pure Silk

Spring

## PLAZA

**BG10**

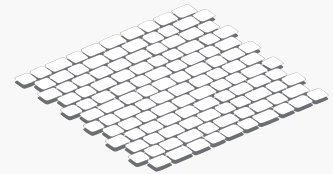

11 3/4" x 12" x 1/4"  
1.0 piece/sqft  
Tile depth: 1/4"

Tile surface: Matte  
Interlocking tile.

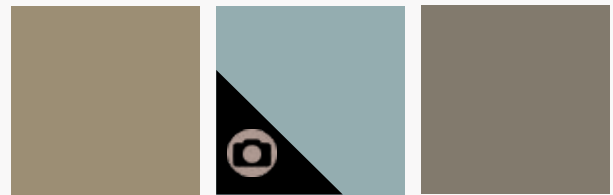

Sand

Stratos

Cement

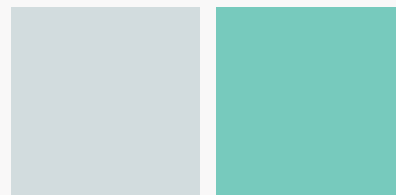

Pure Silk

Spring



# LINEAR

**BG1**

10 1/2" x 12 1/2"  
1.1 pieces/sqft  
Tile depth: 3/16"

Tile surface: Beach texture  
Interlocking tile.

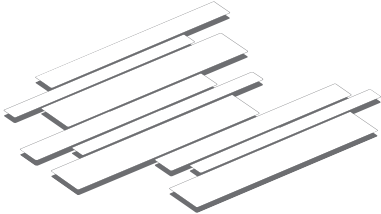

Sand



Frangipani



Seagrass

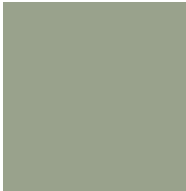

Reed



Breeze

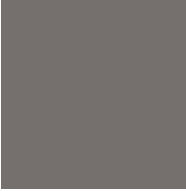

Smoke

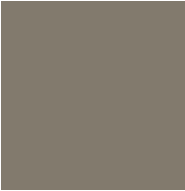

Cement

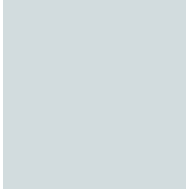

Pure Silk



# BOULEVARD

**BG5**

10 1/4" x 12 1/2"  
1.1 pieces/sqft  
Tile depth: 1/4"

Tile surface: Beach texture  
and gloss  
Interlocking tile.

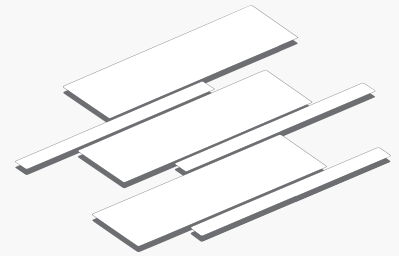

Guava

Frangipani

Seagrass

Reed



Breeze

Smoke

Cement

Pure Silk





## STREAMLINE

**BG8**

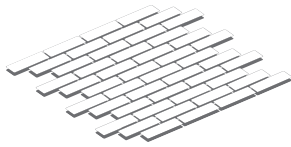

11 3/4" x 12"  
1.0 piece/sqft  
Tile depth: 3/16"

Tile surface: Beach texture  
Interlocking tile.

## CLASSIC

**BG7**

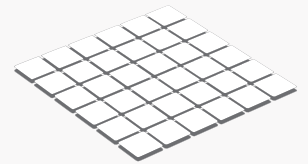

11 3/4" x 11 3/4"  
1.0 piece/sqft  
Tile depth: 1/4"

Tile surface: Beach texture  
Square mosaic tile.



Frangipani

Reed

Breeze



Frangipani

Reed

Breeze



Cement

Pure Silk



Cement

Pure Silk

# GLASS

---

## FORMATS BY COLOR

---

Glass is incredibly versatile: it can be fused into a staggering variety of colors to suit the interiors of any room. We choose to represent the tones often found in nature, such as the sparkling turquoise of a clear lagoon or the rich toned hues of the earth.

This tile is our interpretation of the delicate vibrancy of sea-glass, customized to accent the color scheme of your unique space.



## PURE SILK

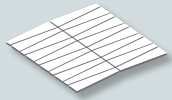

Waveline

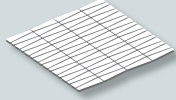

Waveline Mini  
(Matte & Gloss)

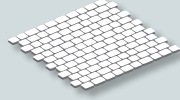

Plaza Mosaic



Linear Mosaic



Palms



Crossroads

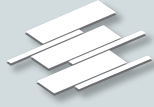

Boulevard Mosaic

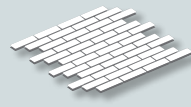

Streamline Mosaic

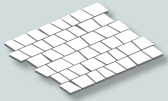

Artifact

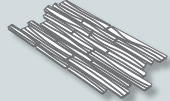

Banyans

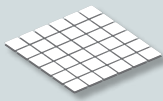

Classic Mosaic



Spindrift

## CEMENT

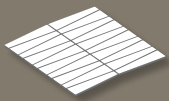

Waveline

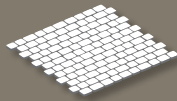

Plaza Mosaic

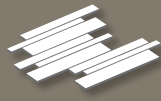

Linear Mosaic

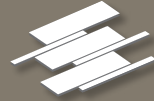

Boulevard Mosaic

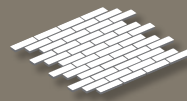

Streamline Mosaic

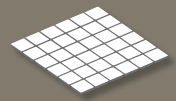

Classic Mosaic

## SAND

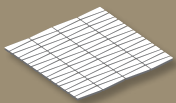

Waveline Mini

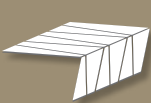

Palms



Crossroads

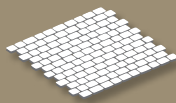

Plaza Mosaic

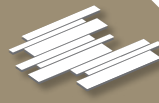

Linear Mosaic

## TULE



Palms

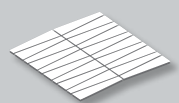

Waveline

## REED

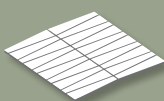

Waveline

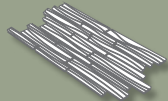

Banyans

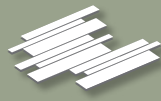

Linear Mosaic



Boulevard Mosaic

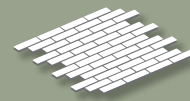

Streamline Mosaic

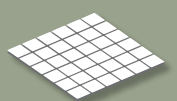

Classic Mosaic

# FRANGIPANI

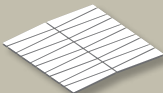

Waveline

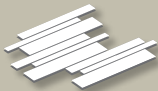

Linear Mosaic

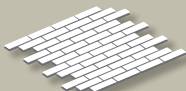

Streamline Mosaic

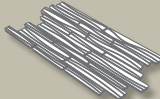

Banyans

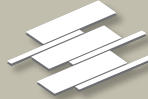

Boulevard Mosaic

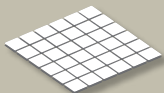

Classic Mosaic

# BREEZE

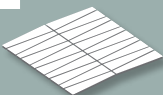

Waveline

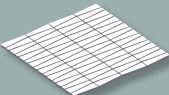

Waveline Mini  
(Matte & Gloss)



Linear Mosaic



Palms



Boulevard Mosaic



Streamline Mosaic

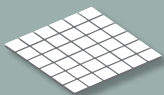

Classic Mosaic

# SPRING

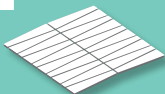

Waveline

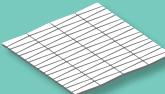

Waveline Mini



Palms

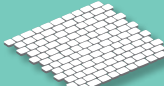

Plaza Mosaic



Artifact



Spindrift

# STRATOS

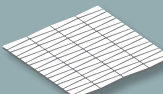

Waveline Mini



Palms



Crossroads

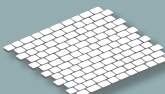

Plaza Mosaic

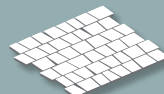

Artifact



Spindrift

# SEAGRASS

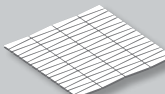

Waveline Mini



Spindrift

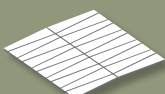

Waveline

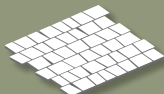

Artifact

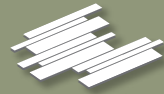

Linear Mosaic



Boulevard Mosaic

# GUAVA

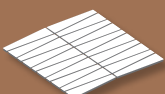

Waveline

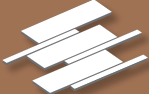

Boulevard Mosaic

# FRESH

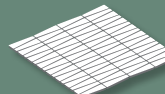

Waveline Mini

## SMOKE

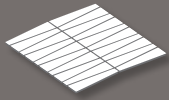

Waveline

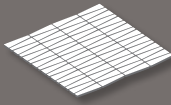

Waveline Mini  
(Matte & Gloss)



Palms



Crossroads

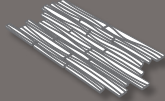

Banyans

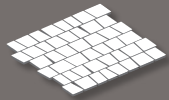

Artifact



Linear Mosaic



Boulevard Mosaic



Spindrift



## MAGARITA

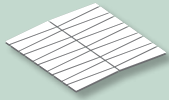

Waveline

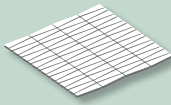

Waveline Mini

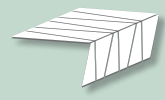

Palms

## AZURE

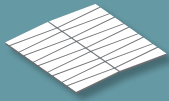

Waveline

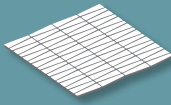

Waveline Mini

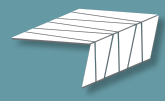

Palms



Spindrift

## OCEANIA

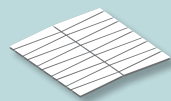

Waveline

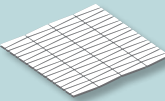

Waveline Mini



Palms

## LAGOON

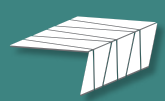

Palms





Island Stone®



A close-up photograph of a stone wall, likely made of granite or a similar natural stone. The stones are rectangular and arranged in a regular pattern. The wall is partially obscured by a dark, diagonal overlay that covers the right side of the image. The text '3 QUARRIED STONE' is overlaid on the dark area.

# 3 QUARRIED STONE

# CLADDING

---

RAW CUT STONE IS BOTH STRIKING AND ENDURING, MAKING IT THE IDEAL MATERIAL FOR EXTERIOR CLADDING SURFACES OR RUSTIC INDOOR INSTALLATIONS.

---

At Island Stone, we first recognized the power of raw stone when individual pieces were placed together to create a dramatic finished surface. Realizing its potential, we slowly perfected the art of precision-cutting every piece and fitting the

stones together with the utmost attention to detail.

The beauty of this series lies in the individual textures, colors, and weight of each stone, which integrate to create a vivid masterpiece.





# STRIP

**CS1**

2" x 11 3/4"

Stone depth: 3/8"

Tile surface: Split face/Craftline/Distressed

Individual rectangular tile.

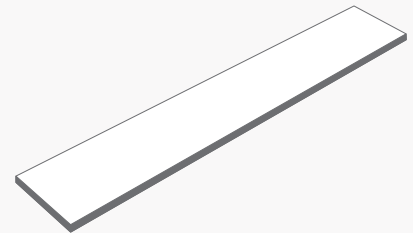

Himachal White  
**HW**



Sandstone Mint  
**SM**



Golden Slate  
**GD**



Rice White Marble  
**JW**



Bali Cream Marble  
**JC**



Copper  
Quartzitic Slate  
**QC**



Silver  
Quartzitic Slate  
**QS**



Himachal Black  
**HB**



Exotic Sands Marble  
**JO**



Volcano Grey Marble  
**JG**



# MINI SPLIT

**CJ4**

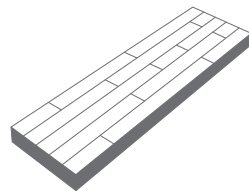

3" x 11 3/4"  
Stone depth: 5/8"  
Tile surface: Split face

Multi piece, glued rectangular tile.

# BRIQ

**CQ3**

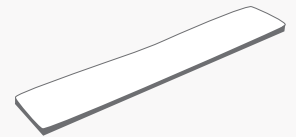

2.5" x 11 3/8"  
Stone depth: 3/8"

Tile surface:  
Honed natural face  
Individual rectangular tile

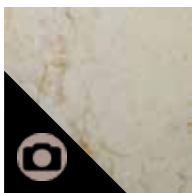

Budi Cream  
**JK**



Volcano Grey Marble  
**JG**



Sandstone Mint Mix  
**SX**



Sandstone Grey  
**SG**

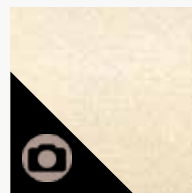

Tropical White  
**WP**

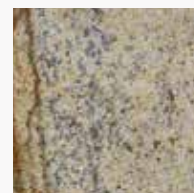

Tropical Tan  
**TP**



## PARALLELS

**CL2**

6 1/2" x 11 1/2"

Stone widths:

1 1/4", 1 7/8", 2 1/2"

Stone depth: 1/2"

Tile surface: Split face

Mesh backed interlocking tile.

Pre-formatted linear pattern.

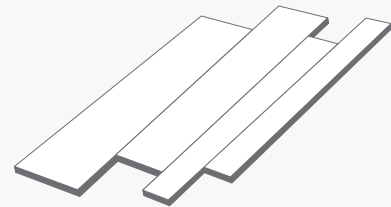

Himachal White  
**HW**



Golden Slate  
**GD**



Sutra Black  
**BM**



Silver  
Quartzitic Slate  
**QS**



# PARALLELS V

**CL3**

6 1/2" x 22 3/4"  
Stone widths:  
1", 1 1/4", 1 7/8", 2 1/2"  
Stone depth: 3/8" - 7/8"

Tile surface: Honed/split face  
Mesh backed interlocking tile.  
Pre-formatted wedge/strip design.

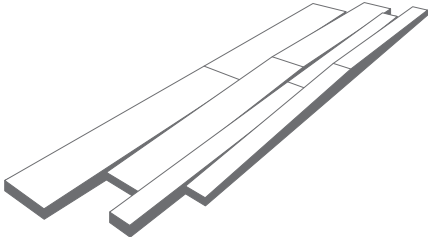

Rice White Marble  
**JW**



Bali Cream Marble  
**JC**



Exotic Sands Marble  
**JO**



Volcano Grey Marble  
**JG**



Tropical White  
**WP**



Golden Slate  
**GD**



Silver  
Quartzitic Slate  
**QS**



Sutra Black  
**BM**



## UNIFORM

**CL1**

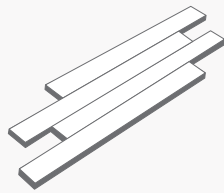

4 3/4" x 15 3/8"  
Stone size: 1 1/2" x 15 3/8"  
Stone depth: 3/8" - 7/8"

Tile surface: Chipped  
Mesh backed interlocking tile.  
Pre-formatted linear pattern.



Sandstone MInt  
**SMC**

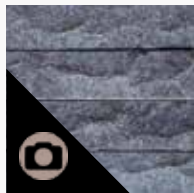

Grey Andesite  
**AGC**

## CROSS STRIPS

**CX1**

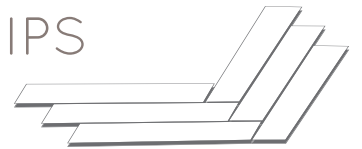

5 5/8" x 20 7/8"  
Stone size: 1 7/8" x 10 1/2"  
Stone depth: 1/2"

Tile surface: Split Face  
Mesh backed interlocking  
tile with pre-formatted  
wedge relief.



Himachal White  
**HW**



Golden Slate  
**GD**

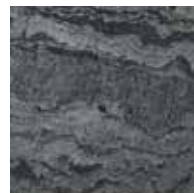

Silver  
Quartzitic Slate  
**QS**





## RUSTIC

**CR1**

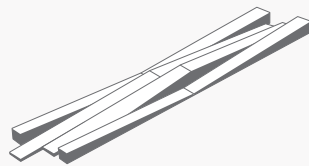

4" x 22 3/4"  
 Stone size: 1" x 11 1/2"  
 Stone depth: 3/8" - 7/8"  
 Tile surface: Split face

Mesh backed interlocking tile.  
 Pre-formatted wedge design.

## RUSTIC II

**CR5**

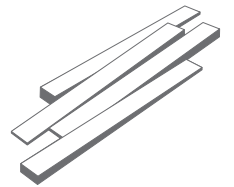

4 3/4" x 15 3/8"  
 Stone size: 1 1/4" x 15 3/8"  
 Stone depth: 3/8" - 7/8"  
 Tile surface: Honed/flamed

Mesh backed interlocking tile.  
 Pre-formatted wedge design.



Sandstone Mint  
**SM**



Sandstone Grey  
**SG**



Golden Slate  
**GD**

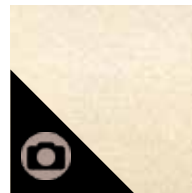

Tropical White  
**WP**



Sandstone Grey  
**SG**



Tropical Tan  
**TP**

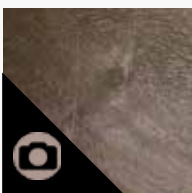

Copper  
Quartzitic Slate  
**QC**



Silver  
Quartzitic Slate  
**QS**



Sutra Black  
**BM**



Island Sage  
**CP**



Flecked Andesite  
(flamed) **AKF**



Temple Lava  
**BL**



## V SQUARES

**CV1**

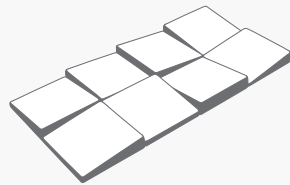

15 1/2" x 7 3/4"

Stone size - 3 7/8" x 3 7/8"

Stone depth: 3/8" - 7/8"

Tile surface - Honed  
Mesh backed tile.  
Pre-formatted wedge design.

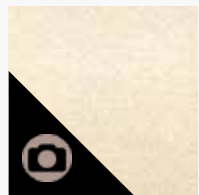

Tropical White  
**WP**



Temple Lava  
**BL**

## SLAT TILE

**CT2**

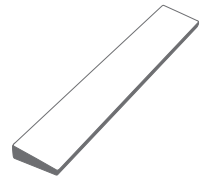

2" x 11 3/4"

Stone depth: 3/8" - 7/8"

Tile surface: Honed  
Individual rectangular tile.  
Inspired by VTile, offering  
wedge relief with angle cut  
across short width.

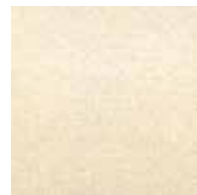

Tropical White  
**WP**



Copper  
Quartzitic Slate  
**QC**

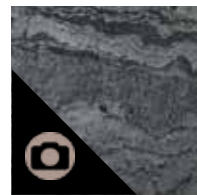

Silver  
Quartzitic Slate  
**QS**



# VTILE

**CR2**

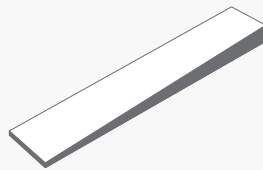

2" x 11 1/2"  
Stone depth: 3/8" - 7/8"

Tile surface: Split face  
Individual rectangle with  
wedge relief.

# VTILE II

**CR7**

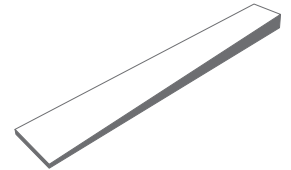

2" x 15 3/8"  
Stone depth: 3/8" - 7/8"

Tile surface: Honed / flamed  
Individual rectangle with  
wedge relief.



Sandstone Mint  
**SM**



Sandstone Grey  
**SG**



Golden Slate  
**GD**

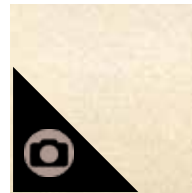

Tropical White  
**WP**



Temple Lava  
**BL**



Copper  
Quartzitic Slate  
**QC**



Silver  
Quartzitic Slate  
**QS**



Sutra Black  
**BM**



# LARGE VTILE

**CR4**

4" x 15 3/8"

Stone depth: 3/8" - 7/8"

Tile surface: Split face  
/ Honed / Flamed

Individual rectangle with  
wedge relief

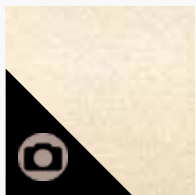
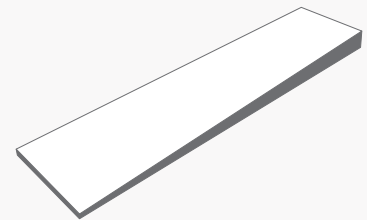

Tropical White  
**WP**



Sandstone Mint  
**SM**



Sandstone Grey  
**SG**



Copper  
Quartzitic Slate  
**QC**



Golden Slate  
**GD**



Temple Lava  
**BL**



Silver  
Quartzitic Slate  
**QS**



Sutra Black  
**BM**



# PROFILES

---

OUR PROFILES SERIES SEAMLESSLY  
COMBINES THOUGHTFUL ENGINEERING  
AND AVANT-GARDE DESIGN.

---

We build eye-catching reliefs by cutting stone into various exact shapes, honing their surfaces, and matching the honed pieces together to create an interlocking system. The rendering often appears 3-dimensional, even sculptural.

A Profile wall elevates texture beyond the traditional limits of stone tile, blurring the line between design and fine art.





## CRESCENT INTERLOCK

**CB1**

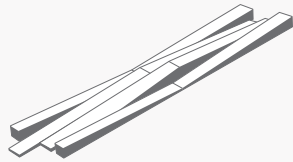

4" x 22 3/4"  
Stone depth: 3/8" - 7/8"  
Stone size: 1" x 11 3/8"

Interlocking wedge tile.  
Tile surface: Honed



Sandstone Mint  
**SM**



Silver  
Quartzitic Slate  
**QS**



Sutra Black  
**BM**

## CRESCENT MINI INTERLOCK

**CB3**

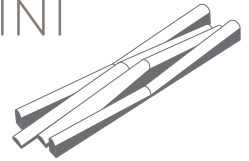

11 7/8" x 3 1/4"  
Stone depth: 3/8" - 7/8"  
Stone size: 3/4" x 5 7/8"

Interlocking wedge tile.  
Tile surface: Honed



Sandstone Mint  
**SM**

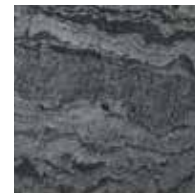

Silver  
Quartzitic Slate  
**QS**



Sutra Black  
**BM**





## CRESCENT VTILE

**CB2**

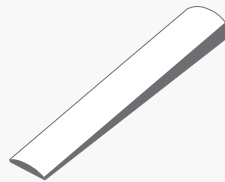

2" x 11 1/2"  
Stone depth: 3/8" - 7/8"

Individual Wedge tile  
Tile surface: Honed



Sandstone Mint  
**SM**



Silver  
Quartzitic Slate  
**QS**

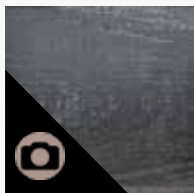

Sutra Black  
**BM**

## RHYTHM INTERLOCK

**MW3**

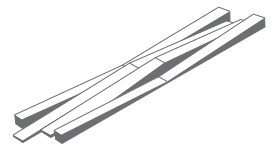

15 3/8" x 3 1/8"  
Stone depth: 3/8" - 7/8"  
Stone size: 15 3/8" x 3/4"

Interlocking wedge tile.  
Tile surface: Honed



Sandstone Mint  
**SM**

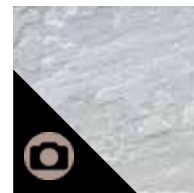

Sandstone Grey  
**SG**



Sutra Black  
**BM**



## DUNES

**DP1**

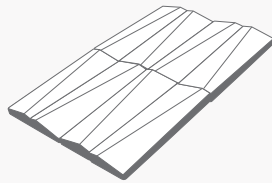

7 1/2" x 11 7/8"

Stone depth: 1/4" - 5/8"

Stone size: 1 7/8" x 5 7/8"

Meshed back interlocking tile with pre-formatted wedge relief  
Tile surface: Honed



Sandstone Mint  
**SM**

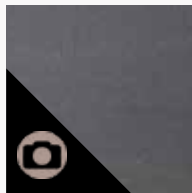

Sandstone Ocean  
**SO**

## NEW WAVE

**MW2**

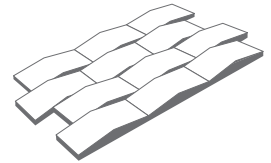

7 1/2" x 11 1/4"

Stone depth: 3/8" - 7/8"

Stone size: 3 3/4" x 1 7/8"

Interlocking Wedge tile  
Tile surface: Honed



White Marble  
**RW**

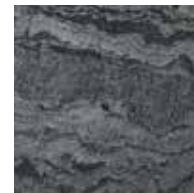

Silver  
Quartzitic Slate  
**QS**



Copper  
Quartzitic Slate  
**QC**

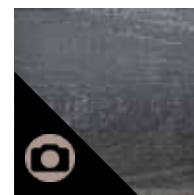

Sutra Black  
**BM**



# PARAGON CHEVRON

**PP1**

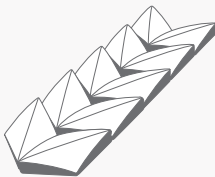

4" x 11 1/2"  
Stone depth: 1/4" - 5/8"

Tile Surface: Honed  
Meshed back interlocking  
tile with pre-formatted  
wedge relief

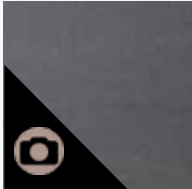

Sandstone Mint  
**SM**

Sandstone Ocean  
**SO**

# PARAGON HEX

**PP2**

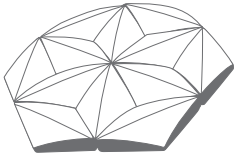

Hex: .38 sq.ft/piece  
Stone depth: 1/4" - 5/8"

Tile Surface: Honed  
Meshed back interlocking  
tile with pre-formatted  
wedge relief



Sandstone Mint  
**SM**

Sandstone Ocean  
**SO**

# MOSAIC

---

OUR CRAFTSPEOPLE HONOR THE AGE-OLD TRADITION OF MOSAIC WITH THE SAME LEVEL OF PERFECTION, PRECISION, AND MODERN SENSIBILITY YOU HAVE COME TO EXPECT FROM ISLAND STONE.

---

We source materials from Indonesia and India, where our artists cut pieces of stone that are then laid out onto a mesh grid to create an easy-to-install single tile. Simple to cut, shape, and customize, this series is an Island Stone interpretation of a beloved classic.





# CLASSIC MOSAIC SQUARES

**M48**

11 3/4" x 11 3/4"  
Stone depth: 1/2"  
Stone size: 1 7/8" x 1 7/8"

Pre-formatted Mosaic tile.  
Tile surface: Honed/split face

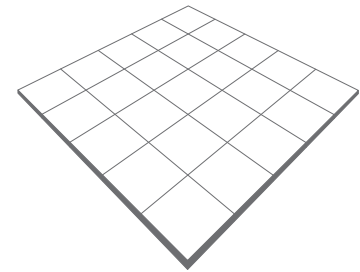

Himachal White  
**HW**

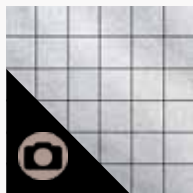

Rice White  
**JW**



Bali Cream  
**JC**



Exotic Sands Marble  
**JO**



Volcano Grey Marble  
**JG**



Himachal Black  
**HB**



Silver  
Quartzitic Slate  
**QS**



Blend: QC/MB/MX  
**S10**



Blend: QS/AGH/  
HW/HB  
**B10**



# AVANT MOSAIC

**M22**

11 3/4" x 11 3/4"  
Stone depth: 1/4"  
Stone size: 1 7/8" x 7/8"

Pre-formatted Mosaic tile.  
Tile surface: Honed stone  
& crinkled glass

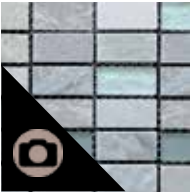
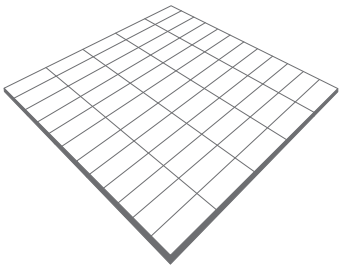

White Ocean  
**HW015**



Copper Earth  
**QC135**

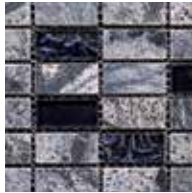

Silver Night  
**QS095**

# QUARRIED STONE

---

BRING AN ELEMENTAL SIMPLICITY TO YOUR SPACE WITH SOLID QUARRIED STONE, A TILE THAT IMPLIES LUXURY WITHOUT AN OUNCE OF FUSSINESS.

---

Our solid stone series is ideal for outdoor and indoor installations with a rustic flair. Imagine showers, fireplaces, floors, and more elevated by the drama of quality stone.

The possibilities are truly limited only by your imagination.

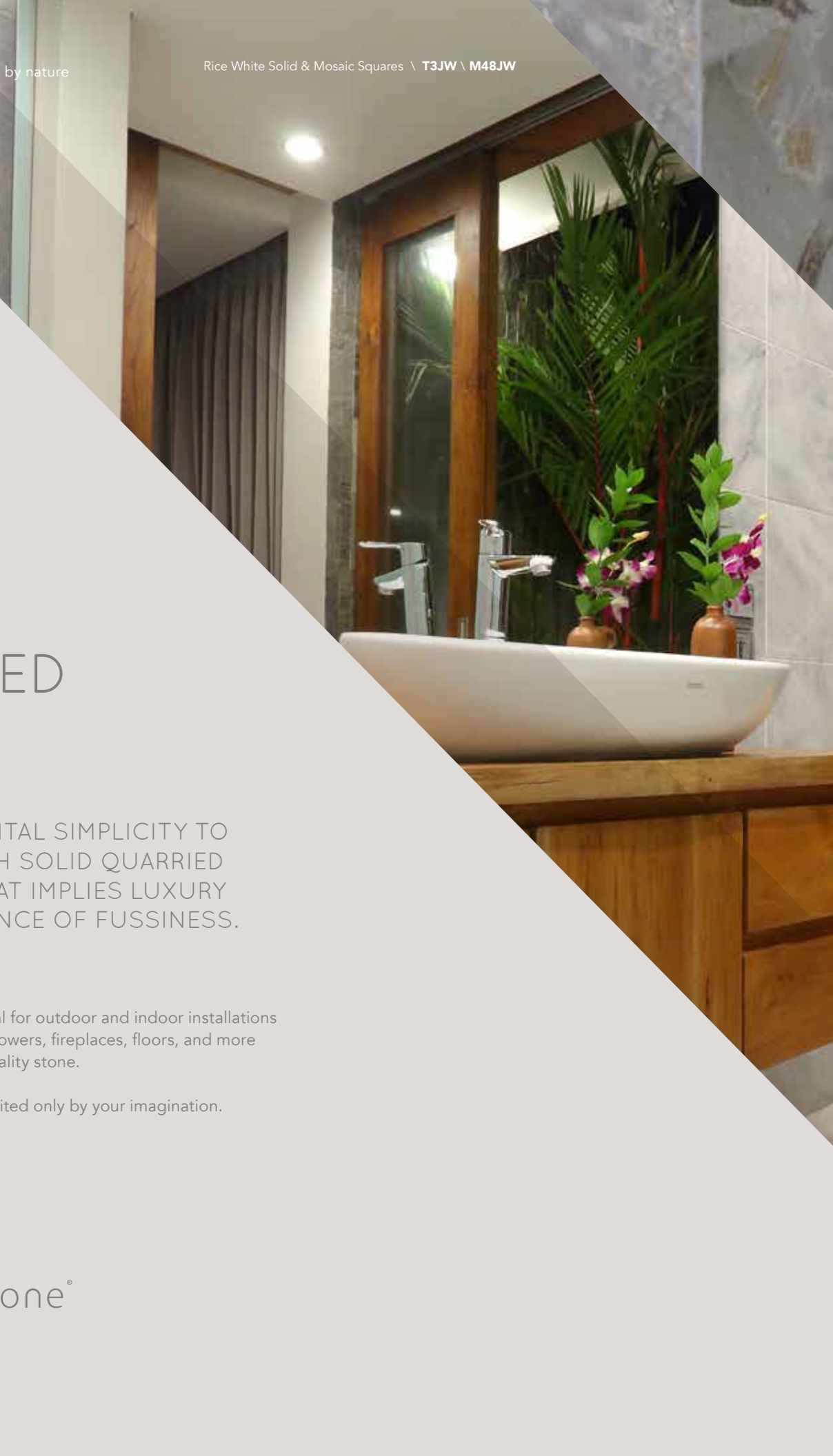







# SOLID TILES

Our Solid Tile range comes in a selection of pre-cut sizes and trims.

## TILES

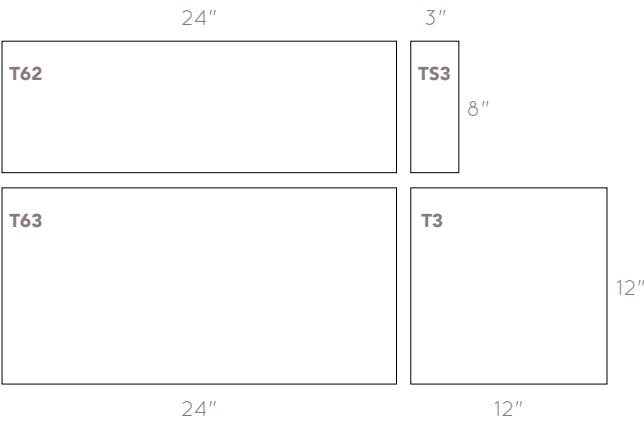

## TRIMS

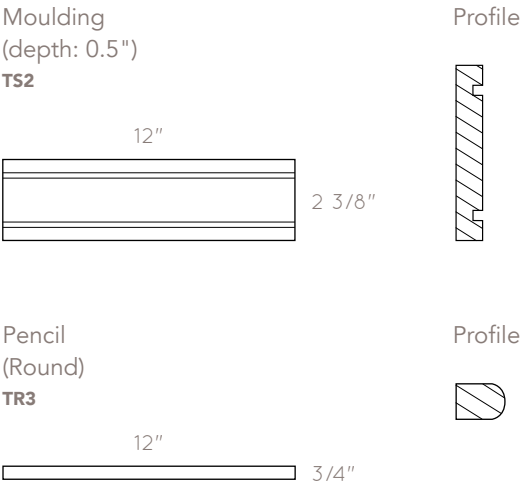

## CUSTOM SIZES

Island Stone offers unmatched capability in working with customers on producing custom sized tiles. For more information see page 139 for additional information on Island Stone custom order capabilities.

# RICE WHITE JW

Tile surface: Honed

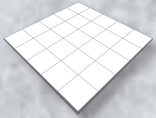

Classic Square  
M48 (Page 70)



Craftline Strip  
CS1 (Page 52)

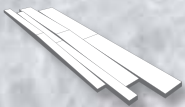

Parallels V  
CL3 (Page 55)

## SOLID STONE TILES

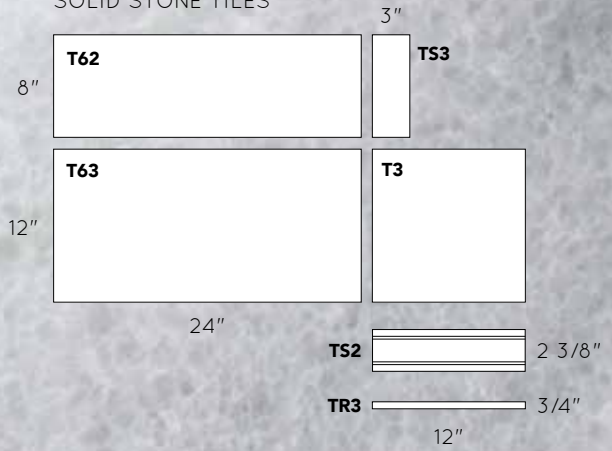

# BALI CREAM JC

Tile surface: Honed

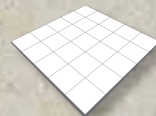

Classic Square  
M48 (Page 70)



Craftline Strip  
CS1 (Page 52)



Mini Split  
CJ4 (Page 53)



Parallels V  
CL3 (Page 55)

## SOLID STONE TILES

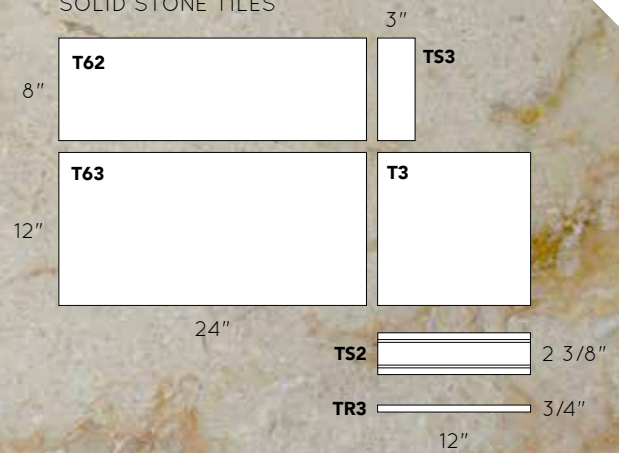

# EXOTIC SANDS JO

Tile surface: Honed



Classic Square  
M48 (Page 70)



Craftline Strip  
CS1 (Page 52)



Parallels V  
CL3 (Page 55)

## SOLID STONE TILES

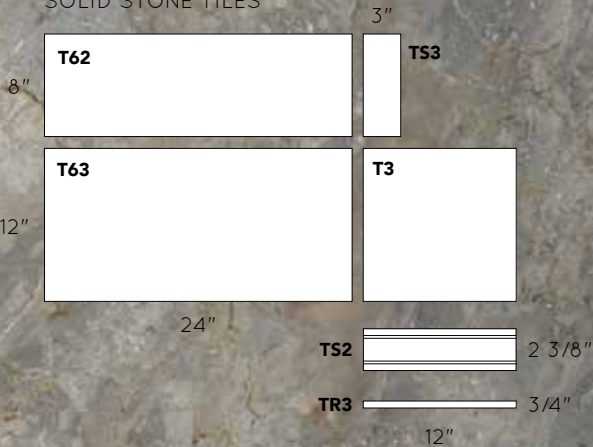

# VOLCANO GREY JG

Tile surface: Honed

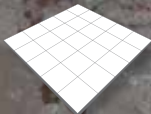

Classic Square  
M48 (Page 70)



Distressed Strip  
CS1 (Page 52)

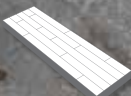

Mini Split  
CJ4 (Page 53)



Parallels V  
CL3 (Page 55)

## SOLID STONE TILES

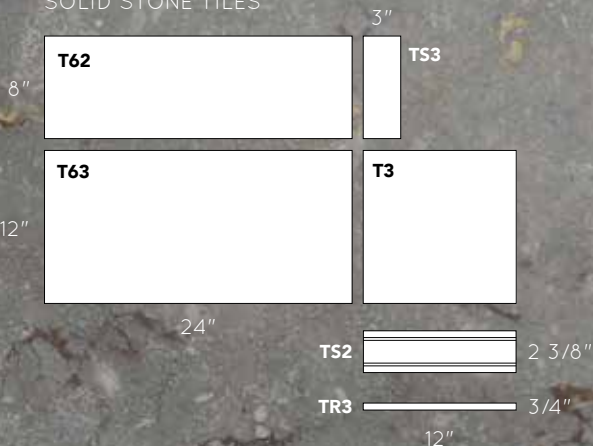

## TROPICAL WHITE

WP

Tile surface: Honed



Rustic II  
**CR5 (Page 57)**



Parallels V  
**CL3 (Page 55)**

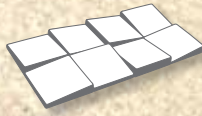

V Squares  
**CV1 (Page 58)**



Briq  
**CQ3 (Page 53)**



Slat  
**CT2 (Page 58)**



VTile II  
**CR2 (Page 59)**



Large VTile  
**CR4 (Page 60)**

## TROPICAL TAN

TP

Tile surface: Honed



Rustic II  
**CR5 (Page 57)**



Briq  
**CQ3 (Page 53)**

## ISLAND SAGE

CP

Tile surface: Honed



Rustic II  
**CR5 (Page 57)**

GREY ANDESITE

AKF / AGC

Tile surface: Flamed & Chipped

Solid Tile Sizes:

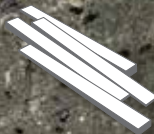

Rustic II  
CR5 (Page 57)

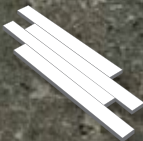

Uniform  
CL1 (Page 56)

TEMPLE LAVA

BL

Tile surface: Honed

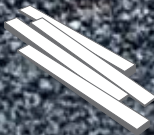

Rustic II  
CR5 (Page 57)

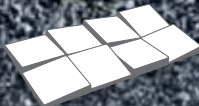

V Squares  
CV1 (Page 58)



Vtile II  
CR7 (Page 59)



Large Vtile  
CR4 (Page 60)

## SANDSTONE MINT SM

Tile surface: Split Face & Honed



Uniform  
**CL1 (Page 56)**



Rustic  
**CR1 (Page 57)**

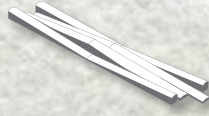

Crescent  
Interlock  
**CB1 (Page 64)**

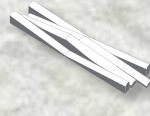

Crescent  
Interlock Mini  
**CB3 (Page 64)**



Strip  
**CS1 (Page 52)**



Rhythm interlock  
**MW3 (Page 65)**



VTile  
**CR2 (Page 59)**



Large VTile  
**CR4 (Page 60)**



Crescent V  
**CB2 (Page 65)**

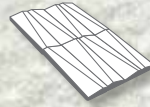

Dunes  
**DP1 (Page 66)**

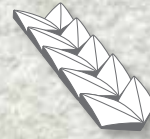

Paragon Chevron  
**PP1 (Page 67)**

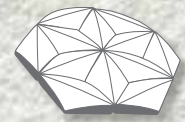

Paragon Hex  
**pp2 (Page 67)**

## SANDSTONE OCEAN SO

Tile surface: Honed

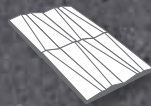

Dunes  
**DP1 (Page 66)**



Paragon Chevron  
**PP1 (Page 67)**

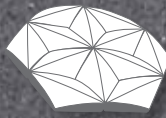

paragon Hex  
**PP2 (Page 67)**



# SANDSTONE GREY

**SG**

Tile surface: Split Face



Rustic  
**CR1 (Page 57)**

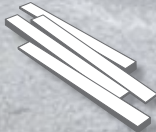

Rustic II  
**CR5 (Page 57)**



Rhythm interlock  
**MW3 (Page 65)**



Briq  
**CQ3 (Page 53)**



Large VTile  
**CR4 (Page 60)**



VTile  
**CR2 (Page 59)**



Briq  
**CQ3 (Page 53)**

# GOLDEN SLATE

**GD**

Tile surface: Split Face



Rustic  
**CR1 (Page 57)**



Parallels  
**CL2 (Page 54)**



Parallels V  
**CL3 (Page 55)**



Cross Strip  
**CX1 (Page 56)**



Strip  
**CS1 (Page 52)**



VTile  
**CR2 (Page 59)**



Large VTile  
**CR4 (Page 60)**

# SILVER QUARTZITIC SLATE SOLID SQUARE

**QS**

Tile surface: Split Face & Honed

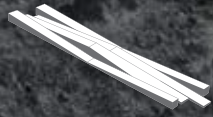

Rustic  
**CR1 (Page 57)**

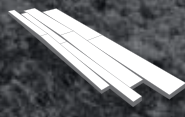

Parallels V  
**CL3 (Page 55)**

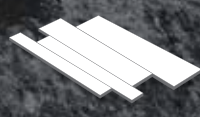

Parallels  
**CL2 (Page 54)**



Strip  
**CS1 (Page 52)**



VTile  
**CR2 (Page 59)**



Crescent VTile  
**cb2 (Page 65)**

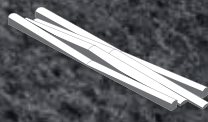

Crescent  
Interlock  
**CB1 (Page 64)**

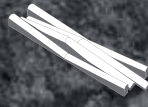

Crescent  
Interlock Mini  
**CB3 (Page 64)**

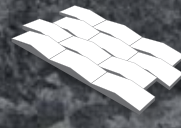

New Wave  
**MW2 (Page 66)**

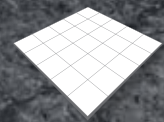

Classic Square  
**M48 (Page 70)**

# COPPER QUARTZITIC SLATE

**QC**

Tile surface: Split Face & Honed



Rustic  
**CR1 (Page 57)**



VTile  
**CR2 (Page 59)**



Large VTile  
**CR4 (Page 60)**



Slat  
**CT2 (Page 58)**

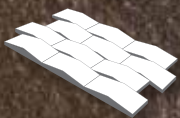

New Wave  
**MW2 (Page 66)**

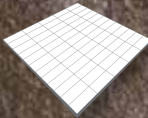

Avant  
**M22 (Page 71)**



Classic Square  
**M48 (Page 70)**

SOLID STONE TILE



Large VTile  
CR4 (Page 60)



Slat  
CT2 (Page 58)

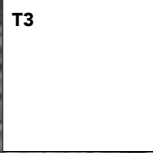

T3  
12"  
12"

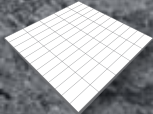

Avant  
M22 (Page 71)



Cross Strips  
CX1 (Page 56)

SUTRA BLACK

BM

Tile surface: Split Face & Honed

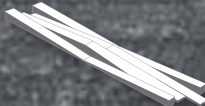

Rustic  
CR1 (Page 57)

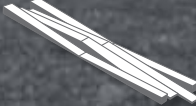

Rhythm interlock  
MW3 (Page 65)

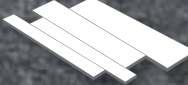

Parallels  
CL2 (Page 54)

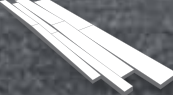

Parallels V  
CL3 (Page 55)



VTile  
CR2 (Page 59)



Large VTile  
CR4 (Page 60)

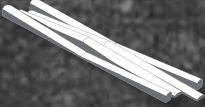

Crescent Interlock  
CB1 (Page 64)

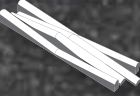

Crescent Interlock Mini  
CB3 (Page 64)



Crescent VTile  
CB2 (Page 65)

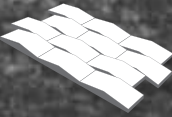

New Wave  
MW2 (Page 66)

# HIMACHAL BLACK HB

Tile surface: Split Face



Strip  
**CS1 (Page 52)**

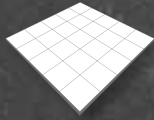

Classic Square  
**M48 (Page 70)**

SOLID STONE TILE

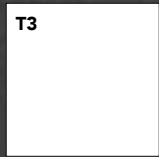

12"

12"

# HIMACHAL WHITE HW

Tile surface: Split Face

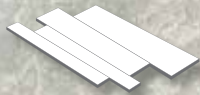

Parallels  
**CL2 (Page 54)**



Cross Strips  
**CX1 (Page 56)**



Strip  
**CS1 (Page 52)**



Classic Square  
**M48 (Page 70)**

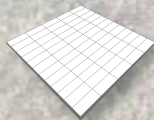

Avant (Split Face)  
**M22 (Page 71)**

SOLID STONE TILE

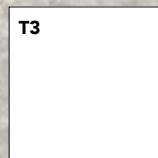

12"

12"

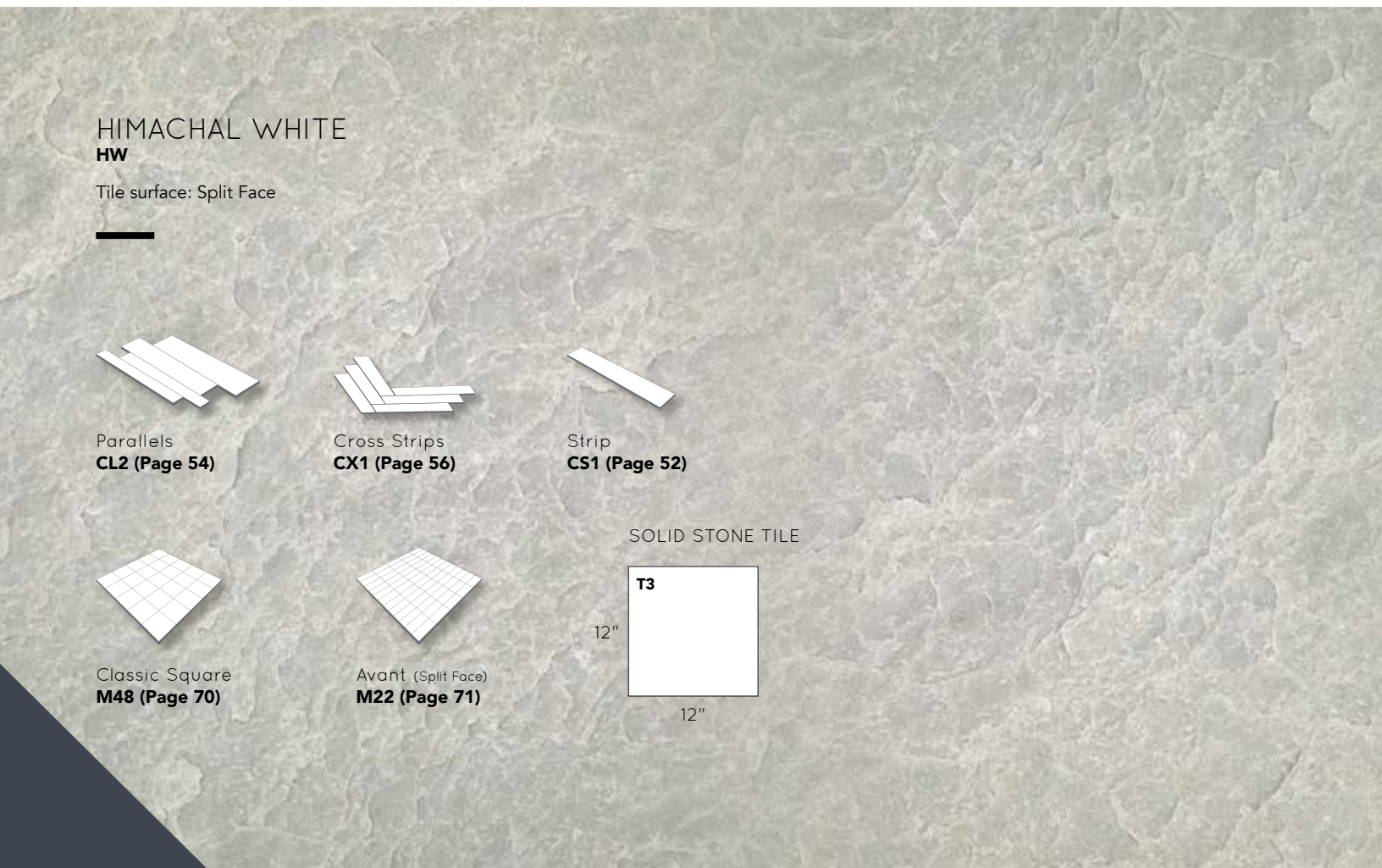





island  
timber

# 4 ISLAND TIMBER



# TIMBER CLADDING

---

ISLAND STONE'S ROOTS IN EXOTIC INDONESIA  
ALLOWED US TO FALL IN LOVE WITH THE  
RUGGED BEAUTY OF OLD GROWTH TEAK WOOD.

---

For centuries, the people of Central Java and Sumatra constructed homes using teak in the traditional "Joglo" design. The wood is as durable today as it was when first felled, making it a perfect option for recycled timber cladding.

We source teak locally from unused homes and buildings, and then restore the timber to its original luster and beauty while

preserving its storied history. Some of our timber displays natural teak colors ranging from light golden hues to weathered, smoky greys; some Island Timber captures the classic, bright painted colors of island homes.

Recycled teak allows your space to tell the story of the islands, and invites you to breathe new life into an ancient material.







## PAPAN PLANKS

**KP1**

Coverage: 10.7 sq.ft/bundle.

Width: 6" (nominal  
dimensions) wide panels of  
varying length

Lengths & quantities of  
panels/bundle:

39 1/2" (3 Panels),  
31 1/2" (2 Panels)  
23 1/2" (2 Panels),  
15 3/4" (2 Panels)

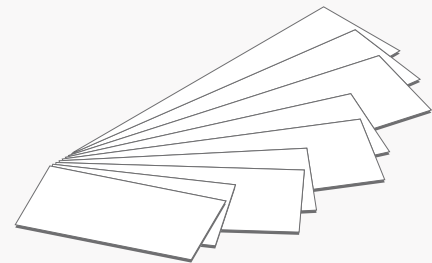

Natural  
**PLS**



Painted  
**WRN**

\* A natural & painted mix is achieved by purchasing desired bundles of each and mixing them during installation.



# RIMBA

**KL3**

15 3/4" x 7 1/8"  
Lengths: 15 3/4"  
Widths: 3 9/16", 2 3/8",  
1 3/16"  
Thickness: (Varied) 1/4- 3/8"

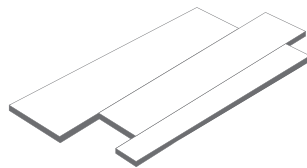

Tile surface:  
Natural and/or painted  
Interlocking tile

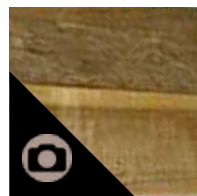

Natural  
**PLS**

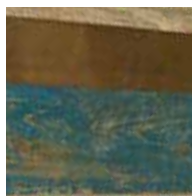

Mixed Natural  
& Painted  
**WRN**

# KAYU V-WOOD

**KR5**

Tile size: 4 3/4" x 15 1/2"  
(3/8" to 7/8" thick wedge).  
Individual pieces: 1 1/8" x  
15 1/2" (3/8" to 7/8" thick  
wedge).

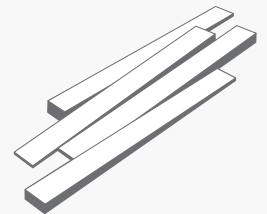

Tile surface:  
Natural and/or painted  
Interlocking tile

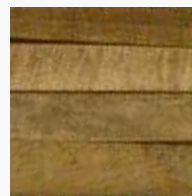

Natural  
**PLS**



Mixed Natural  
& Painted  
**WRN**

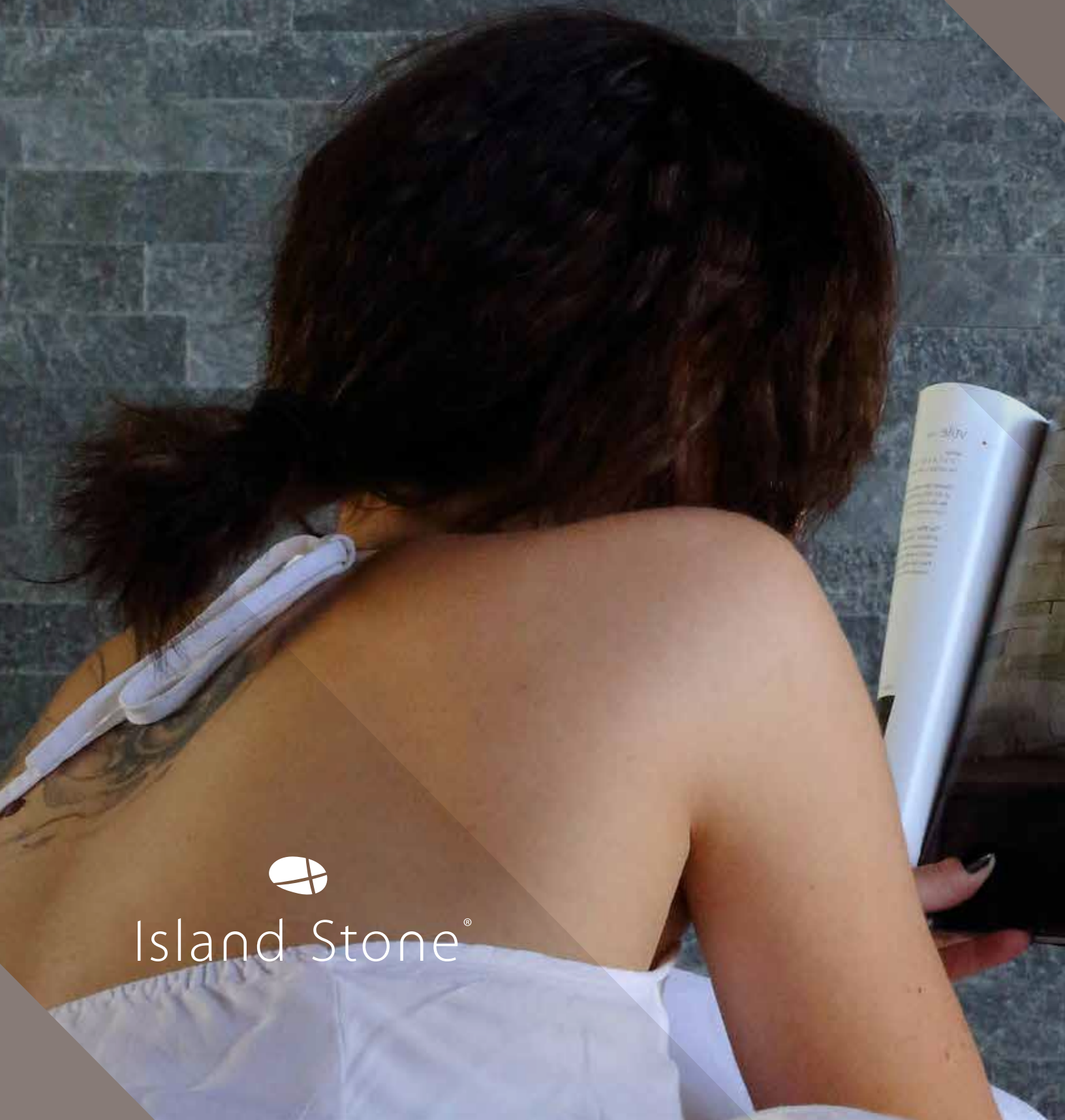

Island Stone®

# 5

INSTALLATION  
INFORMATION

---



# INFORMATION

## PEBBLE & RANDOM

### SEE THE DIFFERENCE

#### Island Stone cut pebble



#### Other un-cut pebble



### PEBBLE TEST RESULTS

Material Code	pa	pc	pf	pg	pm/pw	pn	po	pr	ps	pv
<b>Material Name</b>	Black and Tan Pebble	Medan Charcoal Pebble	French Tan Pebble	Flores Green Pebble	Antique Timor White Pebble	Native Earth Blend	Nightcap Blend	Java Grey Pebble	Sumba Speckled Pebble	Bird's Egg Blend
<b>Description</b>	Blend: pc & pf	Single Pebble	Single Pebble	Single Pebble	Single Pebble	Blend: pf & pr	Blend: pz & pc	Multiple Pebble Mix	Single Pebble	Blend: ps, pm & pg
<b>Pebble/ Hue Variation</b>	High	Low	Medium	Medium	Medium	High	Low	High	Low	High
<b>Exterior Application</b>	Yes	Yes	Yes	Yes	Yes	Yes	Yes	Yes	Yes	Yes
<b>Floor Use (flat and natural surface finishes)</b>	Yes	Yes	Yes	Yes	Yes	Yes	Yes	Yes	Yes	Yes
<b>Water Application</b>	Okay*	Okay*	Okay*	Okay*	Okay*	Okay*	Okay*	Okay*	Okay*	Okay*
<b>Pool Application</b>	No*	Okay*	No*	No*	Okay*	No*	Unknown	Okay*	Okay*	No*
<b>Recommended Sealer</b>	Recommended: Water based low sheen matte finish penetrating stone sealer. Oil based sealers tend to enhance/change color and create glossier finish. All sealers have an effect on color and should be tested on a sample swatch before final application									
<b>Recommended Grout Color/Type</b>	Sanded / Natural Grey	Sanded / Natural Grey	Sanded / Light Tan	Sanded / Light Tan	Sanded / Antique White	Sanded / Light Tan	Sanded / Natural Grey	Sanded / Natural Grey	Sanded / Natural Grey	Sanded / Natural Grey

Material Code	py	pz	cb	cg	ct	cw				
<b>Material Name</b>	Poppy Seed Blend	Alpine Pebble	Medan Charcoal/ French Tan	Flores Green/ Timor White	French Tan/ Medan Charcoal	Timor White /Medan Charcoal				
<b>Description</b>	Blend: pm, pc & pf	Single Pebble	Blend pc & pf	Blend pg & pm	Blend pf & pcx	Blend pm & pc				
<b>Pebble/ Hue Variation</b>	High	Low	High	High	High	High				
<b>Exterior Application</b>	Yes	Yes	Yes	Yes	Yes	Yes				
<b>Floor Use (flat and natural surface finishes)</b>	Yes	Yes	Yes	Yes	Yes	Yes				
<b>Water Application</b>	Okay*	Okay*	Okay*	Okay*	Okay*	Okay*				
<b>Pool Application</b>	No*	Unknown	No*	No*	No*	Okay*				
<b>Recommended Sealer</b>	Recommended: Water based low sheen matte finish penetrating stone sealer. Oil based sealers tend to enhance/change color and create glossier finish. All sealers have an effect on color and should be tested on a sample swatch before final application									
<b>Recommended Grout Color/Type</b>	Sanded / Antique White	Sanded / Natural Grey	Sanded / Natural Grey	Sanded / Light Tan	Sanded / Light Tan	Sanded / Antique White				

\*Okay: Utilizing natural stone in any harsher environment requires following appropriate guidelines as relates to installation and regular maintenance. Always use a qualified installer.  
 \*No : Not Recommended

## FREQUENTLY ASKED QUESTIONS

- Q** Is installing these products difficult to do?  
**A** Product is easy to install. Comprehensive Installation guidelines available online at [www.islandstone.com](http://www.islandstone.com).
- Q** How do you cut Pebble & Random mosaics?  
**A** Use a standard wet tile saw with diamond blade for cutting stone.
- Q** Can product be used on corners and curved surfaces?  
**A** Product is on mesh allowing it be applied to curved surfaces. Tiles are easily cut or hand placed to wrap edges.
- Q** Is product difficult to clean and maintain?  
**A** Product is easy to maintain by regular sealing and can be cleaned with standard household cleaner appropriate for stone.
- Q** How do you clean these products?  
**A** Any basic cleaner is appropriate for these stones. For heavier duty we recommend a cleaner designated for cleaning "Natural Stone".
- Q** Do these product require special maintenance?  
**A** Natural stone maintenance is dependent on the environment. Resealing should occur periodically depending on the environment of the installation. Please refer to sealers for recommendations on when to reseal.
- Q** What is the recommended overage for a project.  
**A** Generally we recommend ordering an additional 10%. For complicated projects involving extensive cutting (many edges) 15% should be considered.

## RANDOM TILE TEST RESULTS

Material Code	fx	ma	mb	mg	ml	mq	mw	mx	mz	qx
<b>Material Name</b>	Forest Marble Mix	Grey Marble	Beige Marble	Tan & Grey Marble	Sterling Grey Marble	Beige Marble & Quartz Mix	Beige & Tan Marble Mix	Tan Marble	Black Basalt	Mixed Quartz
<b>Description</b>	Brown & Green	Single Stone	Stone & Glass	Blend: ma & mx	Single Stone	Blend: mb & qx	Blend: mb & mx	Single Stone	Single Stone	Quartz Blend
<b>Hue Variation</b>	High	low	low	low	low	high	low	low	low	High
<b>Exterior Application</b>		Yes	Yes	Yes	Yes	Yes	Yes	Yes	Yes	Yes
<b>Floor Use (flat and natural surface finishes)</b>	Yes	Yes	Yes	Yes	Yes	Yes	Yes	Yes	Yes	Yes
<b>Water Application</b>	No*	Okay*	Okay*	Okay*	Okay*	Okay*	Okay*	Okay*	Okay*	Okay*
<b>Pool Application</b>	No*	Okay*	Okay*	Okay*	Okay*	Okay*	Okay*	Okay*	Okay*	Okay*
<b>Recommended Sealer</b>	Recommended: Water based low sheen matte finish penetrating stone sealer. Oil based sealers tend to enhance/change color and create glossier finish. For some stone it also brings out unique characteristics. All sealers have an effect on color and should be tested on a sample swatch before final application									
<b>Recommended Grout Color/Type</b>	Natural Grey/ Sanded	Natural Grey/ Sanded	Antique White/ Sanded	Natural Grey/ Sanded	Antique White/ Sanded	Light Tan/ Sanded	Light Tan/ Sanded	Light Tan/ Sanded	Natural Grey/ Sanded	Bright White/ Sanded

Material Code	rw	rz	xd	xf	xl	xx
<b>Material Name</b>	White Marble	White Onyx	Black Forest Mix	French Mix	Sterling MegaMix	MegaMix Quartz & Marble
<b>Description</b>	Single Stone	Single Stone	Blend: fg, mz & ma	Blend: ma, mb & mx	Blend: ml, mb & mx	Blend: mc, mb, mx & qx
<b>Pebble/ Hue Variation</b>	Medium	High	Medium	Medium	Medium	High
<b>Exterior Application</b>	Yes	Yes	Yes	Yes	Yes	Yes
<b>Floor Use (flat and natural surface finishes)</b>	Yes	Yes	Yes	Yes	Yes	Yes
<b>Water Application</b>	Okay*	Okay*	No*	Okay*	Okay*	Okay*
<b>Pool Application</b>	Okay*	Okay*	No*	Okay*	Okay*	Okay*
<b>Recommended Sealer</b>	Recommended: Water based low sheen matte finish penetrating stone sealer. Oil based sealers tend to enhance/change color and create glossier finish. For some stone it also brings out unique characteristics. All sealers have an effect on color and should be tested on a sample swatch before final application					
<b>Recommended Grout Color/Type</b>	Bright White/ Sanded	Light Tan/ Sanded	Light Tan/ Sanded	Light Tan/ Sanded	Antique White/ Sanded	Light Tan

\*Okay: Utilizing natural stone in any harsher environment requires following appropriate guidelines as relates to installation and regular maintenance. Always use a qualified installer.  
 \*No : Not Recommended

# INFORMATION

## GLASS

---

ISLAND STONE GLASS TILES AND MOSAICS ARE CREATED FROM A TRANSPARENT PANE OF GLASS THAT UNDERGOES A PROCESS IN WHICH A LAYER OF COLORED GLASS IS BAKED ONTO THE BACK SURFACE.

Behind the color a second layer of opaque (white) glass is baked to the back surface of the glass to maximize the brightness and allow for a through colored appearance.

## FREQUENTLY ASKED QUESTIONS

---

- Q** Do I need a special contractor to install glass tile?  
**A** Installing glass tile can be done by any qualified tile contractor. Installer should always follow TCNA guidelines to insure the quality of the final installation.
- Q** How do I cut Island Stone Glass?  
**A** Island Stone glass should be cut with a wet saw equipped with a glass specific wet saw diamond blade to eliminate chipping of the tile when cutting. Scorers and snappers (not a saw) can be utilized for making simple cuts with linear designs. Cutting of non linear mosaics should always be done on a wet saw. Format specific techniques for cutting select glass mosaics are included in boxes as well as offered online under "resources at [www.islandstone.com](http://www.islandstone.com)
- Q** What do I do if I chip the glass when cutting?  
**A** Orders should always account for some overage, but for minor chips you can use a diamond sanding block.
- Q** What can I do if I crack a tile once installed?  
**A** A qualified installer can cut out individual tiles using a dremel with a proper bit, but it requires careful handling to not damage other tiles.
- Q** What size grout joints do I use for glass?  
**A** For Mosaics, joints between tiles should match spacing on meshed sheet. For Beach tiles we generally recommend 1/16" - 1/8" grout lines
- Q** Are there special requirements for installation cleanup?  
**A** Special attention should be made when finishing a glass installation to insure no grout haze remains on surface- as once dry, grout can become more visible and affect finished installation.
- Q** How do I clean my glass tile?  
**A** Any standard glass cleaner can be used for regular cleaning. For heavier duty cleaning we recommend using FILA PS87 which is a heavy duty tile specific cleaner.
- Q** Is the glass see through?  
**A** The glass is transparent, but behind the color, we adhere an opaque white finish so that it can be applied over any surface without the color of the substrate affecting the brilliance of the tile.
- Q** Can I customize my order?  
**A** Yes we offer custom service, including alternative colors, blends, textures, shapes, size, etc, but require minimum order quantities and lead times to produce.
- Q** What kind of grout should I use?  
**A** While there are many possible options, we recommend using Bright White Sanded grout.  
Recommended Products:  
Grout: Bright White Sanded  
Sealing: Not necessary for glass, we recommend using a specific grout sealer designed for glass tile.  
Please ask your local tile dealer for available options  
Recommended Glass Cleaner : FILA PS87
- Q** Can you use glass in areas that get hot?  
**A** Yes glass will not be adversely affected by normal heated areas in a home.
- Q** Can you drill through glass?  
**A** Yes, you can drill through glass, but should use a specialized bit designed to drill through porcelain and glass to avoid cracking glass during process.
- Q** What is the recommended overage for a project?  
**A** Generally we recommend ordering an additional 10%. For complicated projects involving extensive cutting (many edge) 15% should be considered.
- Q** Beach Tile Specifications ?  
**A** 665 lb Breaking Strength,  
Freeze/Thaw: Passed,  
COF: Dry .83 / Wet .72,  
Resistance to Chemical Substance: Passed.



# INFORMATION

## QUARRIED STONE

---

THE STUNNING FORM OF ISLAND STONE'S QUARRIED STONE INTRODUCES A WHOLE NEW WORLD OF POSSIBILITIES.

Precision-cut, with either a natural or honed surface that enriches the color of the raw material, Island Stone Quarried Stone is truly transformational.

## FREQUENTLY ASKED QUESTIONS

---

**Q** Can I grout claddings?

**A** Yes, generally designed as dry stack, flat surface (non wedge relief) claddings such as Strip can be grouted, but special care required related to cleaning grout during installation on split face finishes

**Q** Do I need to seal claddings?

**A** Depends on use. In exterior or wet environments claddings should always be sealed. Water based penetrating stone sealers are generally recommended, but in environments where stone will face extreme exposure, oil based waterproof penetrating stone sealers may offer better protection. Always test sealer on stone as sealers can dramatically change surface appearance.

**Q** Can natural stone products be used in wet areas?

**A** Yes, approved stones (see chart) can be used in wet environments but should be applied to a waterproofed surface and should be sealed appropriately.

**Q** Can claddings be used on floors?

**A** Yes, flat surface (non wedge relief) claddings can be used on floors.

**Q** What size grout joints do I use for solids?

**A** Grout joints can vary to fit the look one is trying to achieve, we generally recommend between 1/16"-1/4".

**Q** How do I turn corners with claddings?

**A** Both miter cuts and butt joints are options. For details visit our online resources section at [www.islandstone.com](http://www.islandstone.com)

**Q** Are honed finished Solids tiles okay for floors?

**A** Solids can be used for floors. For COF specifications visit our online resources section at [www.islandstone.com](http://www.islandstone.com)

**Q** Can materials be used on curved surfaces?

**A** Yes, materials can be applied to a curved surface. Direction and length of product used, define the minimum radius required for material to fit curve.

**Q** Can you install material on any surface?

**A** Material should only be applied to a solid, immobile surface. If applying to drywall, we recommend first covering wall with a solid concrete board. If applying to a unique surface material make sure adhesive used is designed to work with both the tile and surface.

**Q** What is the recommended overage for a project?

**A** Generally we recommend ordering an additional 10%. For complicated projects involving extensive cutting (many edge) 15% should be considered.

## QUARRIED STONE TEST RESULTS

Material Code	jc, jcc, jch	jg, jgc, jgh	jk	jo, joc, joh	jw, jwc, jwh	rw	wp	cp	tp	agc, agh, agx, akf &ax14s
<b>Material Name</b>	Bali Creme Marble	Volcano Grey Marble	Budis Creme Marble	Exotic Sands Marble	Rice White Marble	White Marble	Tropical White	Island Sage	Tropical Tan	Grey and Flecked Andesite (chipped)
<b>Description</b>	Indonesian Marble						Indonesian Limestone			Indonesian volcanic stone
<b>Hue Variation</b>	Low	Medium	Low	Medium	High	Medium	Low	Medium	Medium	Low
<b>Exterior Application (Free Thaw approved)</b>	*No	*No	*No	*No	*No	Okay*	Okay*	Okay*	Okay*	Okay*
<b>Water Application/ Pool Application</b>	Okay*	Okay*	Okay*	Okay*	Okay*	Okay*	*No	*No	*No	Okay*
<b>Recommended Grout Color/Type</b>	Sanded/ Light Tan	Sanded/ Natural Grey	Sanded/ Light Tan	Sanded/ Light Tan	Sanded/ Bright White	Sanded/ Bright White	Sanded/ Antique White	Sanded/ Antique White	Sanded/ Light Tan	Sanded/ Natural Grey

Material Code	bl	sm, smc	sg	so	hw, hw01s	hb	qc, qc13s	qs, qs09s	gd	bm & bm03s
<b>Material Name</b>	Temple Lava	Sandstone Mint	Sandstone Grey	Sandstone Ocean	Himachal White	Himachal Black	Copper Quartzite	Silver Quartzite	Golden Slate	Sutra Black
<b>Description</b>	Indonesian volcanic stone	Indian Sandstone			Indian Quartzite		Indian Slate			
<b>Hue Variation</b>	Low	Low	Low	Low	High	Low	Low	Low	High	Low
<b>Exterior Application (Free Thaw approved)</b>	*No	Okay*	Okay*	Okay*	Okay*	Okay*	Okay*	Okay*	Okay*	Okay*
<b>Water Application/ Pool Application</b>	Okay*	*No	*No	*No	Okay*	Okay*	*No	Okay*	*No	Okay*
<b>Recommended Grout Color/Type</b>	Sanded/ Natural Grey	Sanded/ Antique White	Sanded/ Natural Grey	Sanded/ Natural Grey	Sanded/ Bright White	Sanded/ Natural Grey	Sanded/ Light Tan	Sanded/ Natural Grey	Sanded/ Light Tan	Sanded/ Natural Grey

Material Code	s10	b10
<b>Material Name</b>	Tan Square Blend	Grey Square Blend
<b>Description</b>	Blend: qc, mb, mx	Blend: qs, ag, hw & hb
<b>Hue Variation</b>	Low	Low
<b>Exterior Application (Free Thaw approved)</b>	Okay*	Okay*
<b>Water Application/ Pool Application</b>	*No	Okay*
<b>Recommended Grout Color/Type</b>	Sanded/ Natural Grey	Sanded/ Natural Grey

\*Okay: Utilizing natural stone in any harsher environment requires following appropriate guidelines as relates to installation and regular maintenance. Always use a qualified installer.  
 \*No : Not Recommended

# VTILE

## OPENING A NEW DIMENSION IN DESIGN

Arguably the most versatile natural stone material on the market, its unique 3-dimensional structure offers designers a myriad of approaches to creating dramatic contemporary designs. The points below outline what areas to consider when looking to create original distinctive VTILE designs.

### LAYING DIRECTION

**Vertical**

- Popular with smaller, taller surfaces, vertical VTILE designs give surface a stronger, imposing presence.

**Horizontal**

- The most common approach, bringing a wall to life with a distinct eye-catching background.

**Varying directions**

- Creates a complex illusion of shapes as light plays over the crisscrossed wedges.

### PROFILE - PLACEMENT



**Wave**

- Placing VTILES back to back to create an undulating surface with a natural personality.



**Stack**

- Placing VTILES in the same directional manner to create powerful geometric designs.

### ELEVATION - OFFSETS

How an individual VTILE is placed as relates to the piece placed prior.

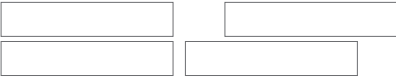

0% offset      25% offset



50% offset



100% offset (wave design only)

## VTILE SINGLE & MULTIFORMAT INSPIRATION

A small selection of the many popular, easy to install layouts for VTILES.



**VTILE - Stacked**  
25% offset



**VTILE - Wave**  
25% offset



**VTILE - Stacked**  
100% offset, opposing directions



**VTILE & Large V - 1 to 1 stacked**  
50% offset



**VTILE & Large V - 1 to 1 wave**  
50% offset



**VTILE & Large V - 2 to 1 stacked**  
50% offset, opposing directions

# INFORMATION

## ISLAND TIMBER

---

OUR WALL CLADDINGS ARE DESIGNED EXCLUSIVELY FOR WALLS AND/OR OTHER NON-TRAFFIC AREAS.

Panels and claddings are cut to a minimal thickness to offer a lightweight, versatile design. Surfaces are finished with a light coating to protect and enhance the product's appearance.

## FREQUENTLY ASKED QUESTIONS

---

**Q** How do I install Island Timber products?

**A** Island Timber wood panels and claddings can be used on virtually any clean, flat and sealed surface. All timber products are designed to be permanently applied to a wall or ceiling. We recommend using an adhesive along with nails to adhere. Detailed instructions are available on our website.

**Q** Where can I use Island Timber?

**A** Island Timber wall claddings are designed exclusively for walls and/or other non traffic areas.

- Residential interior walls: Living room, bedroom room, kitchens and bathrooms.
- Commercial interior walls.
- Exterior. Teak is renown for its resilience to weather, but all wood will weather over time and tile installed in adverse or high exposure areas will require maintenance to keep product from deteriorating.
- Not recommended: High heat environments, wet environments, exposure to chemicals.

**Q** Who do I hire to install Island Timber?

**A** Tile installers or general contractors can install Island Timber products by following our instructions provided in detail on our website.

**Q** Can I use this in an area that has fire rating requirements?

**A** We have tested the ¼" thick teak and received back a "B" fire rating which is acceptable for most projects.

**Q** Where is the wood from?

**A** We salvage our reclaimed teak from homes in Indonesia that have previously been torn down.

**Q** Do I need to seal?

**A** No, sealing is not required. Teak contains natural oil that maintains its appearance. If used in an exterior installation, occasional re-application of teak oil is recommended.

**Q** Can I use for flooring?

**A** Use on floors is not recommended due to the thin design of the products.

**Q** Can material be used on a fireplace?

**A** Material can be used in areas of fireplace that are not exposed to flames such as facade.

**Q** Can wood be stained/painted after application?

**A** Product is sold as finished. Application of additional finishes is not recommended.

**Q** Can I get custom colors?

**A** Custom colors or single colors are available as a special order.

**Q** Does product need to acclimate before being applied?

**A** A one week acclimation period is recommended.

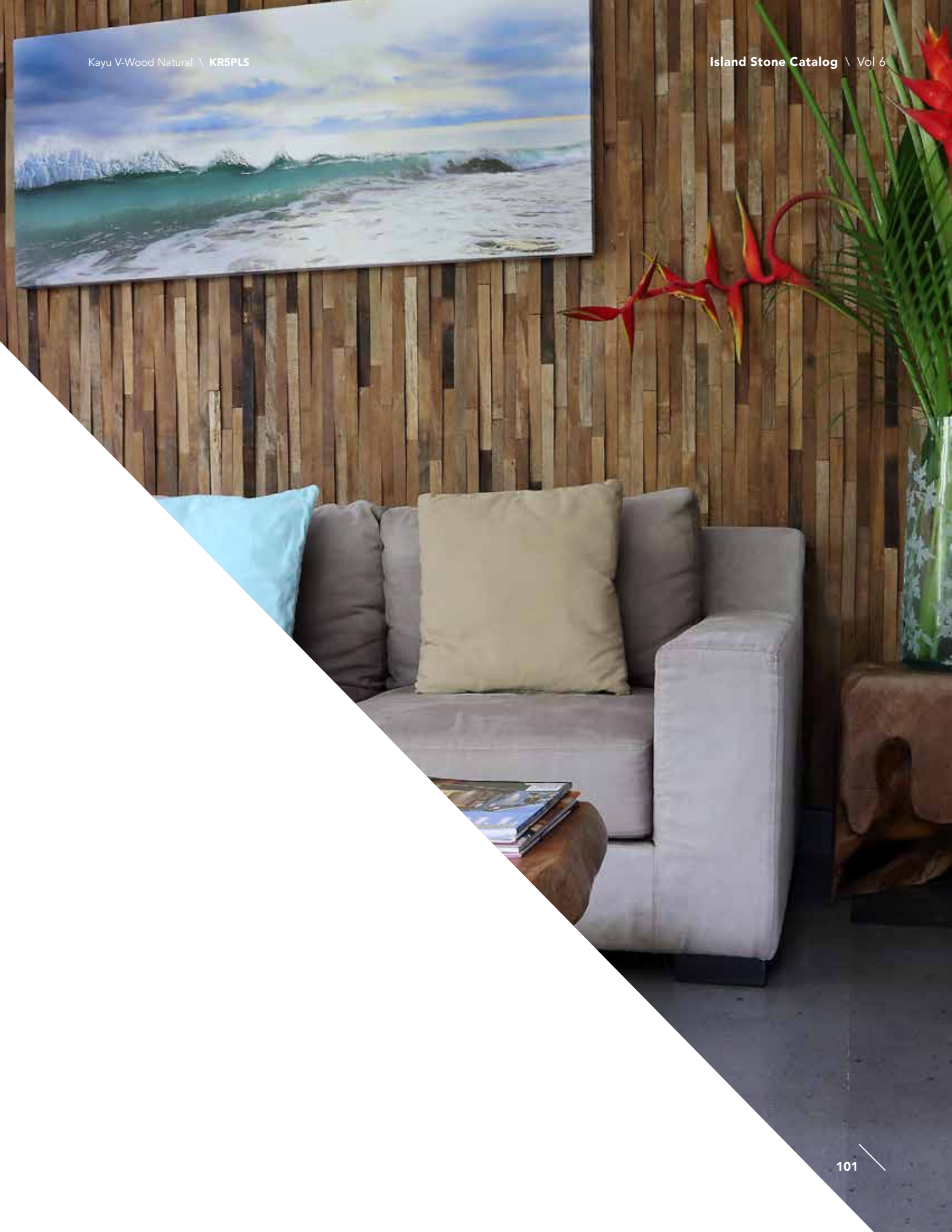



# THANK YOU

---

ISLAND STONE'S PHILOSOPHY REVOLVES AROUND CONTINUALLY RE-INVENTING OURSELVES AND EMBRACING NEW MEDIUMS THAT BOTH COMPLIMENT AND ELEVATE OUR ORIGINAL ICONIC PEBBLE.

---

None of this innovation would be possible without the partnerships we have created around the world with creative, hard working, and compassionate people. Our exotic roots provide a continuous inspiration that moves us to share the rich beauty of Indonesia, our adopted island home.

Thank you for continuing to support Island Stone and Island Timber, and for believing in the pebble that would launch a 20-year business. We hope you enjoy the products made possible by inspired design, perseverance, and partnership.







Island Stone®

---

FOR FURTHER INFORMATION OR  
YOUR NEAREST SUPPLIER PLEASE VISIT:  
[ISLANDSTONE.COM](http://ISLANDSTONE.COM)

Note: While every effort has been made to capture a true likeness to color,  
color samples and photographs seen in this publication may not be an exact color match of product.  
All images © Island Stone International Ltd, 2015. | © Island Stone International Ltd, 2015. All rights reserved.